

OPERATORS HANDBOOK

INDEX

	PAGE NUMBER
Specifications	1
Lifting and Installation Instructions	2
Floor Plan	4
Electrical Diagram	5
Lubrication	7
Lathe Safety	11
Operating Instructions	14
Maintenance Instructions	23
Parts Ordering Procedure	29
Electrical Parts List	30

ASSEMBLY DRAWINGS AND PARTS LISTS

	<u>DRAWING #</u>	
General Assembly	B-113927	32
Final Assembly	B-113930	32A
End Gear Train	E-85691	33
Control Shafts.	B-113928	34
Headstock (18 speed)	E-85068	35
Headstock Shifters (Sheet 1)	D-85069(1)	36
Headstock Shifters (Sheet 2)	D-85069(2)	37
Headstock Shifters (Sheet 3)	D-85069(3)	37A
Apron (Sheet #1)	114660-1	38
Apron (Sheet #2)	114660-2	39
Apron (Sheet #3)	114660-3	40
Feedbox	E-84302	41
Saddle/Crosslide Assy.	B-115925	42
Compound Slide Assy.	114938	43
Tailstock	D-43280	44
Telescopic Taper Turning Attachment	E-85005	45
Faceplate 26" - 4 slots	C-43241	46
Instruction Sheet - Cutler-Hammer Brake		47
" " " "		48

1. LIFTING AND INSTALLATION INSTRUCTIONS

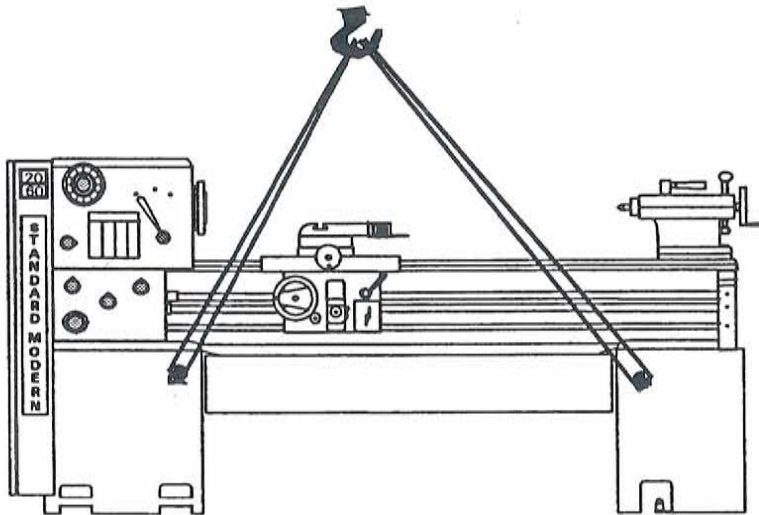

1.1 Lifting the Machine

The machine should be lifted using rope slings as shown with the rear splash guard removed and with the carriage and tailstock assemblies placed (as shown) to give an equilibrium condition under the lifting hook. Protect painted surfaces with thick pads and wood blocks.

Do not attempt to lift this machine with a hoist having less than two ton capacity. The shipping weight of the machine is approx. 60" lathe - 5,500 lbs; 80" lathe - 5,800 lbs; 120" lathe - 6,100 lbs.

Do not remove skids from the machine until it is brought to its final position, especially if the machine is to be moved on rollers.

1.2 Inspection

Check your delivery slip against the accessories that were ordered with the machine. If there is a shortage or error, report it to STANDARD-MODERN LATHES INC. immediately, giving the serial number of the machine which is stamped in the recessed face on top of the bed at the tailstock end of the machine.

1. LIFTING AND INSTALLATION INSTRUCTIONS cont'd

1.3 Cleaning

All unpainted parts of the machine have been coated with an anti-rust compound. This should be thoroughly removed after the machine is installed and before moving the carriage, compound rest or tailstock.

To remove anti-rust compound, wipe with a clean cloth.

All unpainted surfaces should be coated immediately with a film of light machine oil to prevent rust.

1.4 Installation

For proper operation, the machine should be set on a substantial floor capable of supporting a uniform pressure of 50 P.S.I. To secure the machine on its foundation use anchor bolts or lag screws as shown on Floor Plan.

After the machine is in position, it must be leveled by use of the square head set screws provided, before tightening the lag screws. It will be necessary to use 4-inch square steel plates, about 3/4" thick, under the leveling screws to prevent the ends of the screws from sinking into the floor.

Use a precision level placed lengthwise and crosswise on the bed. To take a reading of the level for the crosswise leveling of the bed, use parallel bars placed on the flats of the bed.

After leveling within 0.0005 in/ft, the pedestals should be lagged to the floor and the leveling rechecked. Re-check the level of the machine at regular intervals.

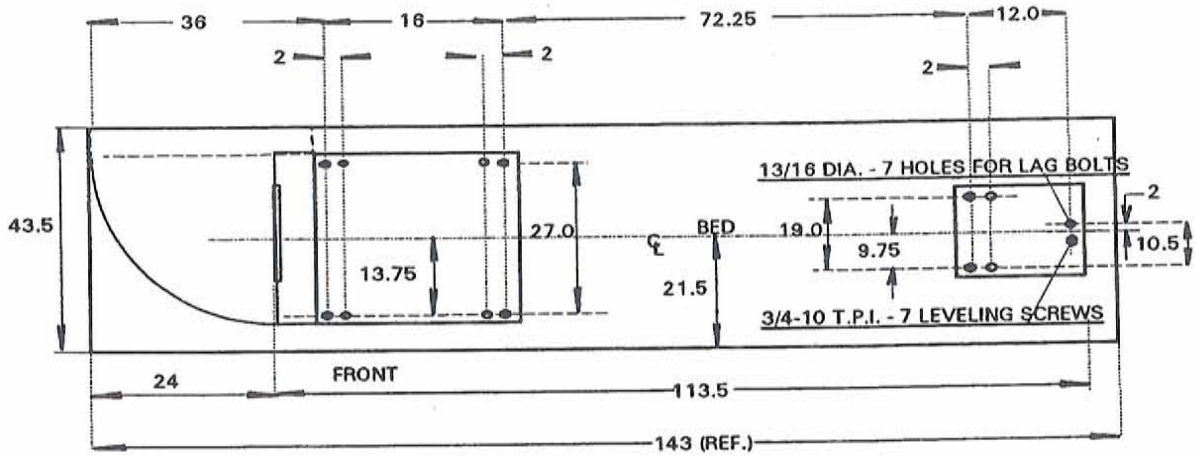

2060 LATHE

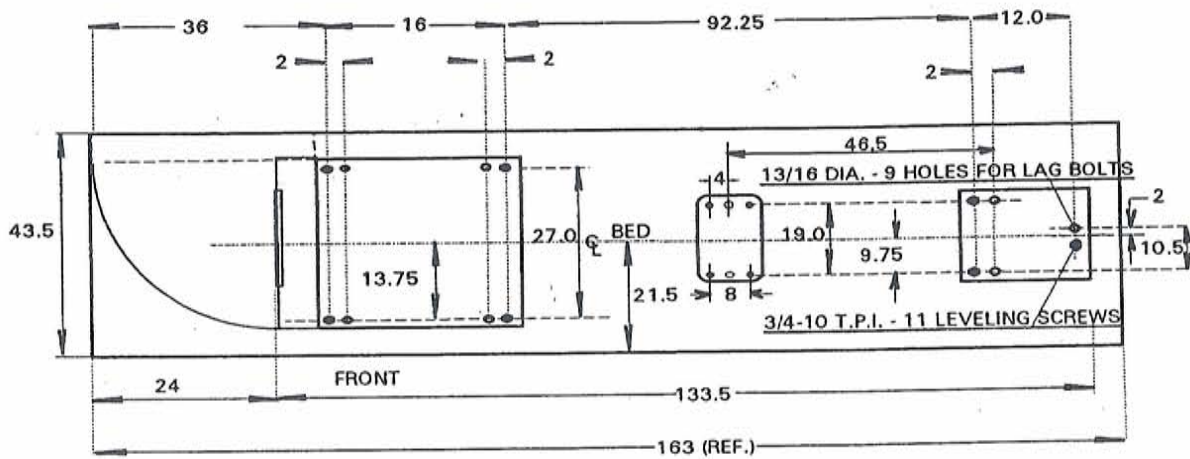

2080 LATHE

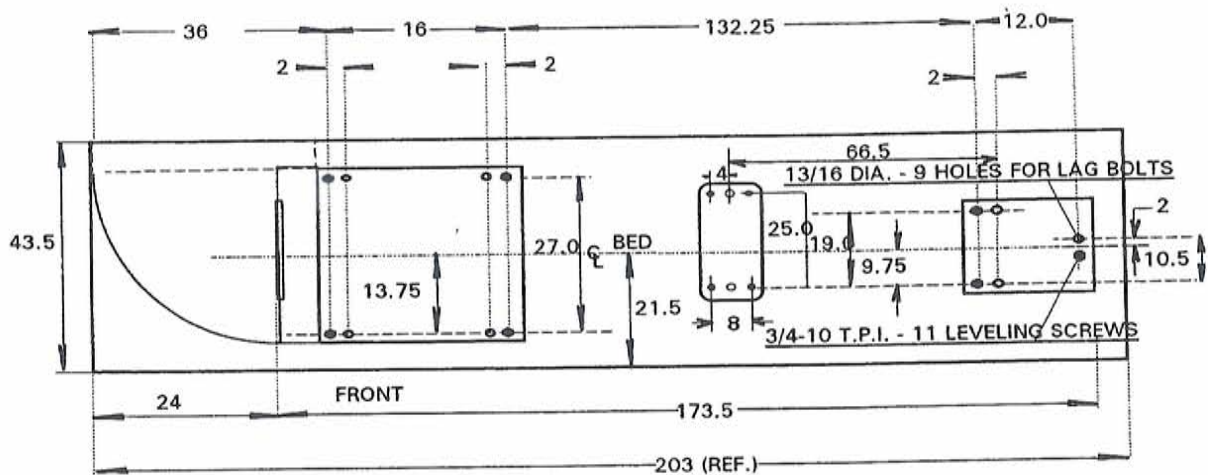

20/120 LATHE

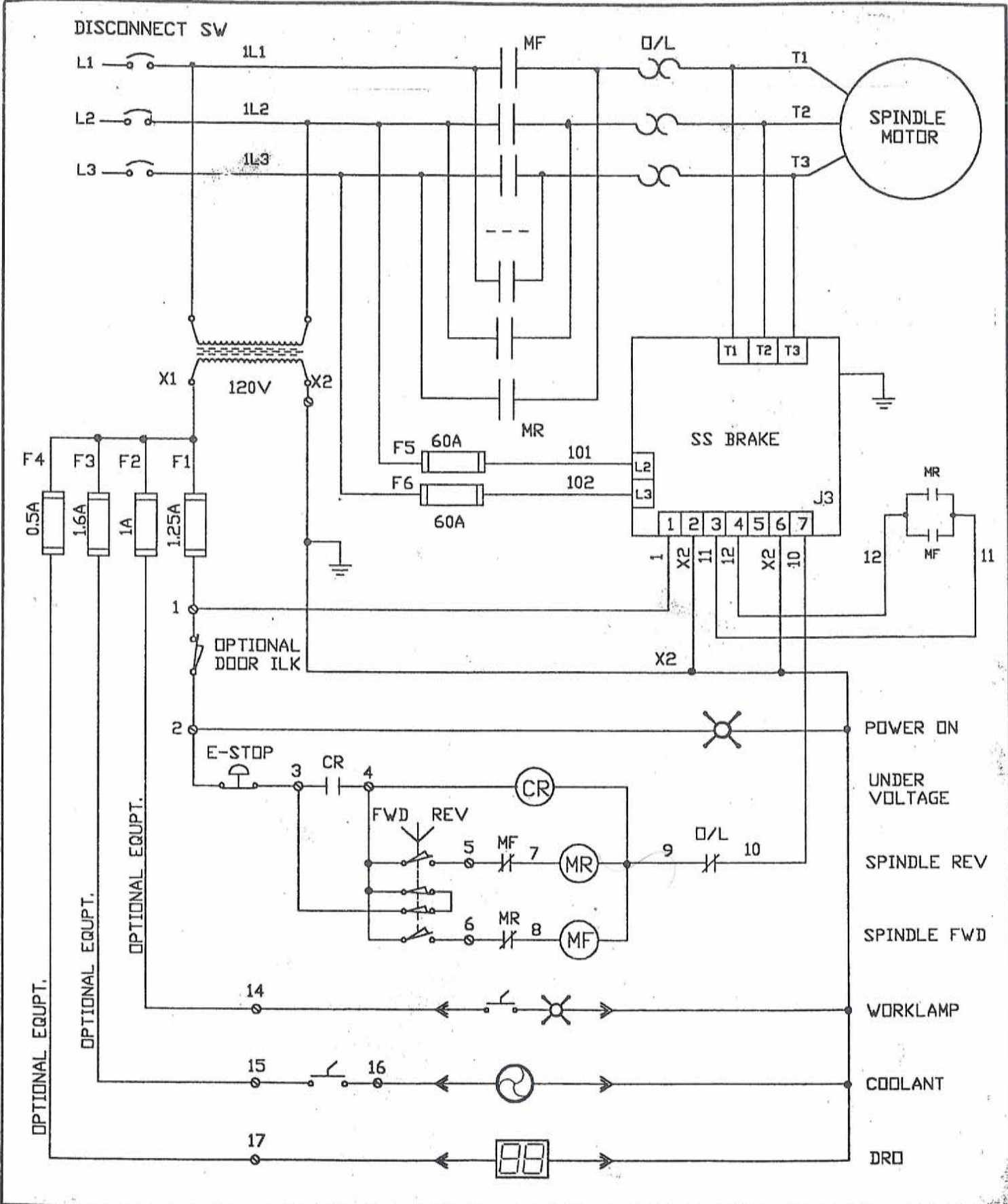

STANDARD-MODERN LATHES INC. Ontario, Canada		ELECTRICAL SCHEMATIC
DRN A.P.	TITLE 20 INCH LATHE WITH SOLID STATE BRAKE	FIRST USED ON JOB NO.
DATE MAY 04	STANDARD WIRING	A-119551

THIS PAGE INTENTIONALLY LEFT BLANK.

2. LUBRICATION



OIL SAE 30 Non-detergent Mineral Oil
 Viscosity 500-550 SUS at 100°F
 MIL-L 6082D GRADE 1100
 NSN: 9150-21-888-7172



GREASE: Lithium base with or without E.P. additives.
 MIL-G-1092C MIL-G-46006

THE FOLLOWING POINTS SHOULD BE LUBRICATED EVERY
 8 WORKING HOURS

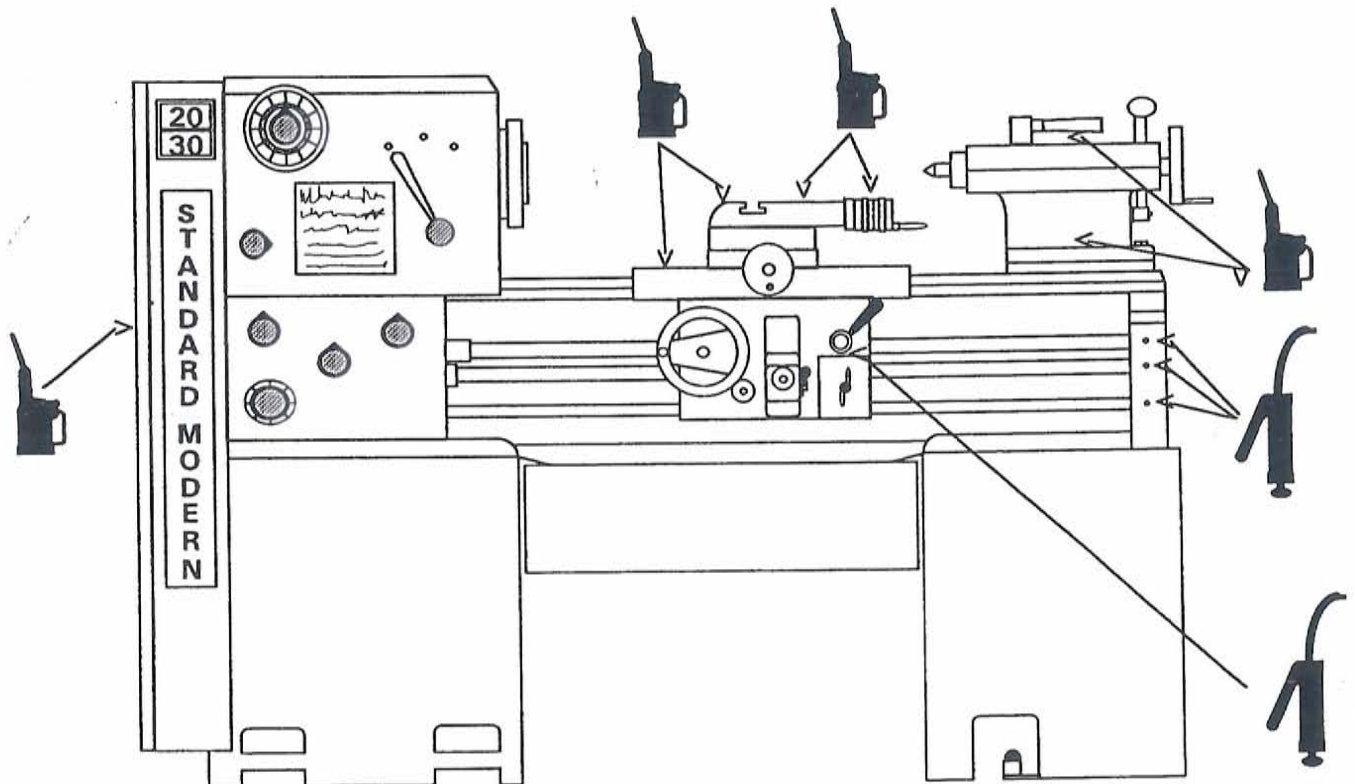

NOTE: Telescopic taper attachment not shown

EVERY SIX MONTHS CHANGE OIL

Headstock	10 quarts
Feed box	3 quarts
Apron	1 quart

EVERY MONTH

Leadscrew reverse	linkage pivot
Leadscrew reverse	cam track

2. LUBRICATION

2.1 General

NOTE- Always turn the main disconnect switch OFF before opening the belt guard.
Access to the following requires the belt guard to be open.

Headstock filler.	1-1/2" Pipe plug.
Feedbox filler.	1/2" Pipe plug.
Leadscrew reverse cam.	Grease fitting and track.
Leadscrew reverse linkage pivot.	Oil.

Before filling reservoirs or oil cups, always wipe off any accumulation of old oil, grease or dirt that might get into a part being lubricated.

Depending on operating conditions, usually about every six months, the Headstock, Feedbox and Apron should be drained and thoroughly flushed out , before adding new oil.

Because most solvents tend to soften paints, they are not recommended as flushing media. A light mineral oil, to which a small percentage of kerosene has been added, may be used to flush out any dirt or sediment. Run the machine for several minutes without load so that the flushing oil can circulate through the reservoir. The flushing oil should then be drained and new oil added.

2.2 END GEAR TRAIN

Oil idler gear teeth daily.

2.3 Apron

The oil level should be checked and replenished daily as the one shot lubrication system draws its oil from this reservoir in order to lubricate the saddle and cross slide ways.

The apron oil reservoir should be drained, flushed and refilled with fresh clean oil at least once every six months.

One grease nipple located on the right hand end of the apron lubricates the half-nut control shaft. A second grease nipple lubricates the leadscrew reverse control hub.

2.4 Tailstock

The spindle and screw are lubricated by an oiler located on top of the spindle housing. The bed ways on which the tailstock slides should be cleaned and oiled frequently.

Dry red lead mixed with machine oil to a creamy consistency is an excellent lubricant for the tailstock center when a revolving center is not available.

2.5 Compound

On the compound rest, remove the pipe plug in the top face to lubricate the ways and the screw. Replace the pipe plug after applying oil. A ball type oiler lubricates the screw bearing.

2.6 Cross Slide

The cross slide dovetails and bearing surfaces are lubricated by the one shot lubrication system located in the apron. One oiler, at the center on top of the cross slide lubricates the Cross Feed Nut and the threaded portion of the Cross Feed Screw. The cross feed screw bearing is lubricated through an oiler behind the cross feed dial.

2.7 Saddle

The saddle ways are lubricated by means of the one shot lubrication system through oil passages and oil grooves.

The oil is retained at the bearing surfaces by felt seals located at either end of the saddle wings which also provide an even distribution of the lubricant over the ways.

2.8 Bed End Bracket and Leadscrew

Three grease fittings, located on the front face of the Bed End Bracket, lubricate the ends of the Leadscrew, Feed Shaft, Control Shaft, Leadscrew Reverse Shaft and Trip cam.

Before cutting a thread, clean and oil the Leadscrew thoroughly.

2.9 Leadscrew reverse linkage

The leadscrew reverse linkage and cam are serviced after opening/removal of the belt guard.

Once per month, grease should be applied to the top of the operating bar, the cam track and the grease nipple in the operating cam body. The pivot should also be lightly oiled at this time.

2.10 Taper Attachment

Clean and oil the pivoted slide bar before using.

Four oilers lubricate the slide plate and the thrust bearing.

Fill the elbow oil cup located at the back of the sliding block and pivot bolts.

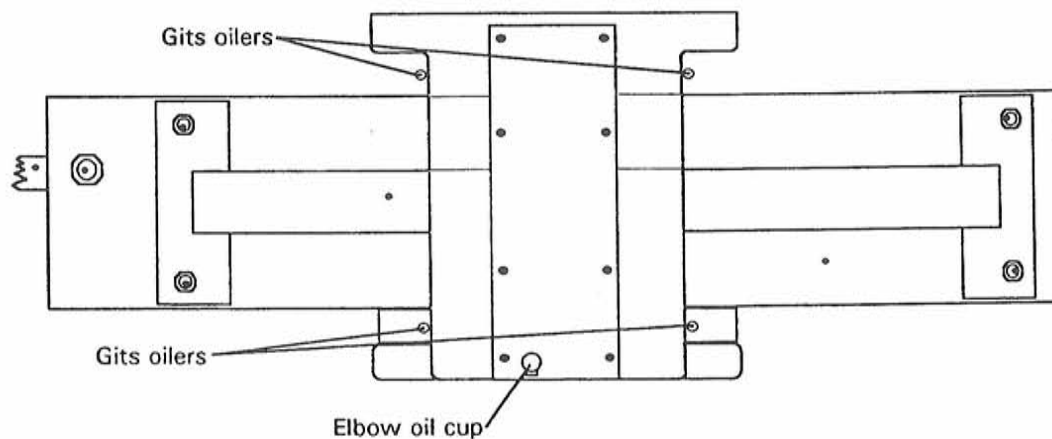

3. LATHE SAFETY

Every effort has been made in the design and production of the lathe to comply with statutory safety requirements and to provide a fundamentally safe machine tool. In the further interests of safety, attention should be given to the following notes:

3.1 Machine Use

Responsibility for the following points with respect to machining a component must inevitably rest with the user.

- (1) Ensure that the operator has had suitable training and possesses the required degree of skill and experience to undertake the work.
- (2) Provide suitable work holding and/or supporting equipment : chucks, steadies, revolving centers, etc.
- (3) Ensure that suitable tooling is provided and correctly mounted.
- (4) Ensure that suitable feeds and speeds are selected.
(If in doubt select low).
- (5) Provide and use suitable workpiece guards.

3.2 Lathe Safety Rules

- (1) Read and understand operation notes before attempting to use the machine.
- (2) Keep lathe work areas clean.
- (3) Keep area surrounding machine tidy.
- (4) **KNOW HOW TO STOP THE MACHINE BEFORE STARTING IT.**
- (5) **DO NOT** interchange chucks or other spindle mounted items between lathes without checking for correct locking.
- (6) We recommend only high speed chucks.
- (7) Before operating the lathe, note the maximum rated speed for chucks and face plates as supplied by the manufacturer.
- (8) Remove chuck key immediately after use.
- (9) Check load capacity of revolving centers.
- (10) Ensure guards are in position before starting machine.
- (11) **DO NOT** use cracked or chipped tools.
- (12) **CHECK** before starting motor:
 - Spindle speed and feed rate selected.
 - Feed and thread cutting levers are disengaged.
- (13) **STOP MACHINE IMMEDIATELY IF ANYTHING UNEXPECTED HAPPENS.**
- (14) **DO NOT** use coarse feed range on high spindle speeds.
- (15) **DO NOT** change spindle speeds when spindle is rotating.
- (16) **DO NOT** touch revolving chuck, spindle or workpiece.

3. LATHE SAFETY cont'd.

- (17) DO NOT remove work from the machine without retracting the tool to a safe position.
- (18) Stop motors and push in red safety stop switch when leaving machine unattended.
- (19) Use safety stop switch when changing workpiece, tightening or loosening chuck etc.

3.3 Personal Safety Rules

- (1) Report any accident as soon as it happens.
- (2) Wear safety glasses.
- (3) Wear safety shoes.
- (4) Use barrier creams provided.
- (5) Wear your overalls buttoned up.
- (6) Roll sleeves up or button the cuffs.
- (7) Keep hair short or wear a cap.
- (8) Use the correct size wrench at all times.
- (9) Be careful of, and remove, all burrs and sharp edges.
- (10) When lifting a heavy workpiece, use the correct type of sling, ensuring that it is not worn or damaged and that its safe working load is not exceeded.
- (11) Stand clear when lifting workpieces or equipment by crane.
- (12) Obtain assistance when mounting heavy or awkwardly shaped workpieces.
- (13) DO NOT wear rings, watches, ties, etc.
- (14) DO NOT keep tools (scribers, etc.) in overall pockets.
- (15) DO NOT remove guards unless machine is stationary.
- (16) DO NOT wash hands in coolant.
- (17) DO NOT remove chips with bare hands; use a rake or brush.
- (18) DO NOT manually lift heavy equipment.
- (19) DO NOT use files, scrapers, etc., on machine tools.
- (20) DO NOT lean on the machine.
- (21) DO NOT tamper with electrical equipment.

4. OPERATING INSTRUCTIONS

4.1 Motor and Spindle Control

The spindle motor is controlled by means of a two control levers. The L.H. motor control causes forward rotation and stop. It is intended primarily for jogging when changing gear.

The R.H. motor control, mounted on the apron, is Lifted up for FORWARD rotation, centralize for STOP and push down for REVERSE rotation. In the central or stop position, a fail safe brake is engaged.

4.2 Spindle Speed Selection

Slow Range	27	35	45	55	70	90	115	150	190
High Range	240	300	380	480	600	775	1000	1250	1600

The desired spindle speed range is obtained by moving the 3-Position Handwheel. Any spindle speed within that range can be obtained by moving the 3-Position Selector Knob and the High-Low Shifter.

For free hand rotation of the spindle, move the High-Low Shifter lever to its vertical position.

WARNING - STOP the motor before operating any speed selectors.

- DO NOT exceed spindle speed recommended by chuck manufacturer.
- DO NOT operate the machine with the large face plate above 480 rpm.

4.3 Power Feeds

The automatic trip clutch pre-load is factory set and should not require adjustment.

A safety interlock is fitted so that it is impossible to engage the POWER FEED ENGAGEMENT LEVER and the HALF-NUTS LEVER at the same time.

4. OPERATING INSTRUCTIONS cont'd

4.3 cont'd

To select power longitudinal feed or power cross feed, arrange the A-B selector knob on the headstock and the C-D-E , F-G-H, W-X-Y-X-Z and 8-Position knob on the feedbox to correspond with the desired feed rate indicated on the "Feeds and Threads" charts on pages 16 and 17

CAUTION: DO NOT USE THE COARSE RANGE OF FEEDS WHEN SPINDLE SPEEDS ARE ABOVE 480 RPM.

(REFER TO PAGE 16 FOR LIST OF FEEDS)

Push in the black ball handle located on front of apron for longitudinal feed or pull out for crossfeed.

Select L.H. longitudinal feed and Out cross feed or R.H. longitudinal feed and In cross feed using the feed and thread direction control lever, situated at the right hand side of the apron.

To engage power, lift the power feed engagement lever. Power feed may be engaged when the spindle is running.

For automatic feed kickout in power feed longitudinal operations, set the Trip Dogs as required.

CAUTION Trip dogs must not be used when spindle is operated in the reverse direction.

CAUTION Do not use this procedure for spindle speeds above 800 rpm.

FEED RATES

A			B		
INCH	(FINE)	MM	INCH	(COARSE)	MM
.0015	EH1X	.040	.027	EG2X	0.69
.0017	EH2X	.045	.030	DF1X	0.76
.0020	EH3X	.050	.033	EG8X	0.84
.0021	EH8X	.053	.034	DF2X	0.86
.0022	EH4X	.055	.035	EG4X	0.89
.0023	EH5X	.058	.037	EG5X	0.93
.0025	EH6X	.060	.038	DF3X	0.97
.0027	EH7X	.070	.039	EG6X	1.00
.0030	EF1X	.080	.042	DF8X	1.07
.0034	EF2X	.085	.043	EG7X	1.09
.0038	DH1X	.095	.044	DF4X	1.12
.0040	EF3X	.100	.046	DF5X	1.15
.0041	EF8X	.104	.049	DF6X	1.24
.0042	DH2X	.107	.053	DF7X	1.35
.0044	EF4X	.110	.060	DG1X	1.55
.0046	EF5X	.115	.068	DG2X	1.73
.0050	EF6X	.125	.076	DG3X	1.91
.0052	DH8X	.130	.083	DG8X	2.10
.0053	EF7X	.135	.087	DG4X	2.22
.0055	DH4X	.140	.091	DG5X	2.30
.0057	DH5X	.145	.098	DG6X	2.48
.0060	EG1X	.150	.105	DG7X	2.67
.0062	DH6X	.155			
.0070	EG2X	.170			
.0075	DF1X	.190			
.0084	EG8X	.200			
.0086	DF2X	.217			
.0088	EG4X	.222			
.0090	EG5X	.230			
.0095	DF3X	.240			
.0099	EG6X	.250			
.0106	EG7X	.260			
.0110	DF8X	.270			
.0114	DF5X	.290			
.0124	DF6X	.310			
.0130	DF7X	.340			
.0150	DG1X	.380			
.0170	DG2X	.430			
.0190	DG3X	.480			
.0210	DG8X	.530			
.0220	DG4X	.550			
.0228	DG5X	.570			
.0250	DG6X	.630			
.0270	DG7X	.670			

THREADS

Threads per inch				mm Pitch			
A		B		A		B	
127	EH1W	7-1/2	CF3Z	.200	EH1W	4.0	DF1W
84	CG7Z	7-1/8	DH1Z	.225	EH2W	4.4	EG8W
78	CG6Z	7	CF7Y	.25	EH3W	4.5	DF2W
72	CG5Z	6-1/2	CF6Y	.275	EH8W	4.6	EG4W
69	CG4Z	6	CF5Y	.2875	EH4W	4.75	CG7W
64	EF1W	5-3/4	CF4Y	.3	EH5W	4.8	EG5W
60	CG3Z	5-1/2	CF8Y	.325	EH6W	5.0	DF3W
56	CG7Y	5-1/4	CH7Z	.35	EH7W	5.5	DF8W
54	CG2Z	5	CF3Y	.4	EF1W	5.75	DF4W
52	CG6Y	4-3/4	DH1Y	.45	EF2W	6.0	DF5W
48	CG5Y	4-1/2	CF2Y	.5	EF3W	6.5	DF6W
46	CG4Y	4-1/8	CH8Z	.55	EF8W	7.0	DF7W
44	CG8Y	4	CF1Y	.575	EF4W	8.0	DG1W
42	CF7Z	3-3/4	CH3Z	.6	EF5W	9.0	DG2W
40	CG3Y	3-1/2	CH7Y	.625	DH3W	10.0	DG3W
39	CF6Z	3-3/8	CH2Z	.65	EF6W	11.0	DG8W
36	CG2Y	3-1/4	CH6Y	.6875	DH8W	11.5	DG4W
33	CF8Z	3	CH5Y	.7	EF7W	12.0	DG5W
32	CG1Y	2-7/8	CH4Y	.71875	DH4W	12.7	CH1Y
34	CF4Z	2-3/4	CH8Y	.75	DH5W	13.0	DG6W
30	CF3Z	2-1/2	CH3Y	.8	EG1W	14.0	DG7W
28	CF7Y	2-1/4	CH2Y	.8125	DH6W		
27	CF2Z	2	CH1Y	.875	DH7W		
26	CF6Y			.9	EG2W		
24	CF5Y			1.0	DF1W		
23	CF4Y			1.1	EG8W		
22	CF8Y			1.125	DF2W		
21	CH7Z			1.1875	CG7W		
20	CF3Y			1.2	EG5W		
19	DF8Y			1.25	DF3W		
18	CF2Y			1.3	EG6W		
16-1/2	CH8Z			1.375	DF8W		
16	CF1Y			1.4	EG7W		
15	CH3Z			1.4375	DF4W		
14	CH7Y			1.5	DF5W		
13-1/2	CH2Z			1.625	DF6W		
13	CH6Y			1.75	DF7W		
12	CH5Y			2.0	DG1W		
11-1/2	CH4Y			2.25	DG2W		
11	CH8Y			2.5	DG3W		
10	CH3Y			2.75	DG8W		
9	CH2Y			2.875	DG4W		
8	CH1Y			3.0	DG5W		
				3.25	DG6W		
				3.5	DG7W		

4. OPERATING INSTRUCTIONS.

4.4 Saddle

Provision is made for locking the saddle when facing by tightening the two 1/2" socket head cap screw shown below.

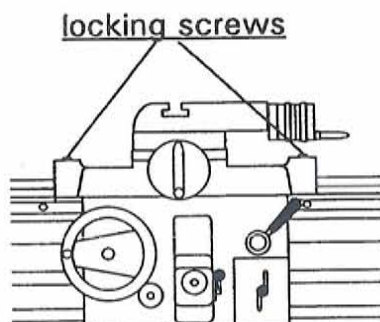

4.5

When cutting screw threads, begin by selecting the desired mm pitch or T.P.I., in a manner similar to feed selection (4.3)

The "Feed and Direction Control Lever" mounted on the extreme right-hand side of the Apron must be moved:

UP for R.H. threads

DOWN for L.H. threads

In the CENTRAL position the entire feed and thread gear train is disengaged.

This lathe is equipped with a leadscrew reversing mechanism which allows half-nuts to remain engaged during the entire threading operation.

4.5 OPERATING INSTRUCTIONS

For automatic thread kickout, set the "Trip Dog" advanced by .44 in. from the final tool position as shown.

CAUTION Trip dogs must not be used when spindle is operated in the reverse direction.

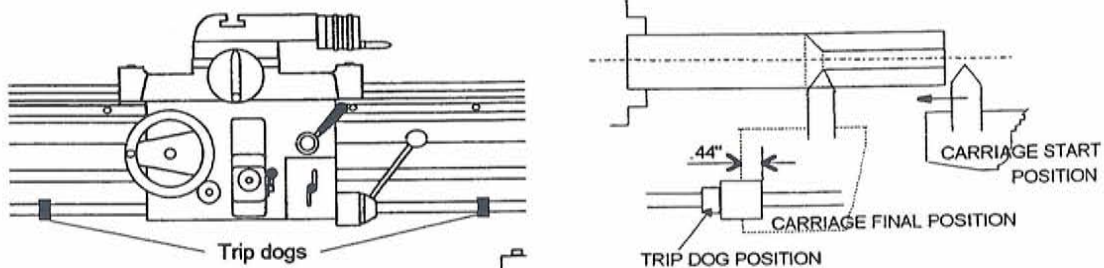

CAUTION: THREADING SPINDLE SPEED LIMIT IS 800 RPM. THE TRIP DOGS OR THE FEED AND THREAD DIRECTION CONTROL LEVER MUST NOT BE ENGAGED ABOVE THIS SPEED.

Approximate safe thread cutting speeds can be determined by using the following formulae:

$$1) \quad \text{T.P.I.} \times 25 = \text{SAFE R.P.M.}$$

$$\text{e.g. } 20 \text{ T.P.I.} \times 25 = 500 \text{ R.P.M.}$$

$$2) \quad \frac{625}{\text{mm pitch}} = \text{SAFE R.P.M.}$$

$$\text{e.g. } \frac{625}{.9 \text{ mm pitch}} = 695 \text{ R.P.M.}$$

CAUTION: DO NOT USE ANY SPINDLE SPEED ABOVE 800 R.P.M. FOR CUTTING THREADS 32 TO 127 T.P.I. OR .9 TO .2 MM PITCH.

4. OPERATING INSTRUCTIONS

4.6 Telescopic Taper Turning Attachment

For Taper Turning:

- (i) Loosen the heavy hex nut on the rear shaft.
- (ii) Locate the saddle on the bed in relation to the workpiece.
- (iii) Locate the slide plate in relation to the workpiece.
- (iv) Tighten the heavy hex nut on the rear shaft.
- (v) Adjust the slide bar to the desired taper and lock securely by means of the four 3/8-socket head cap screws located towards each end.

For Straight Turning

- (i) Loosen the heavy hex nut on the rear shaft.

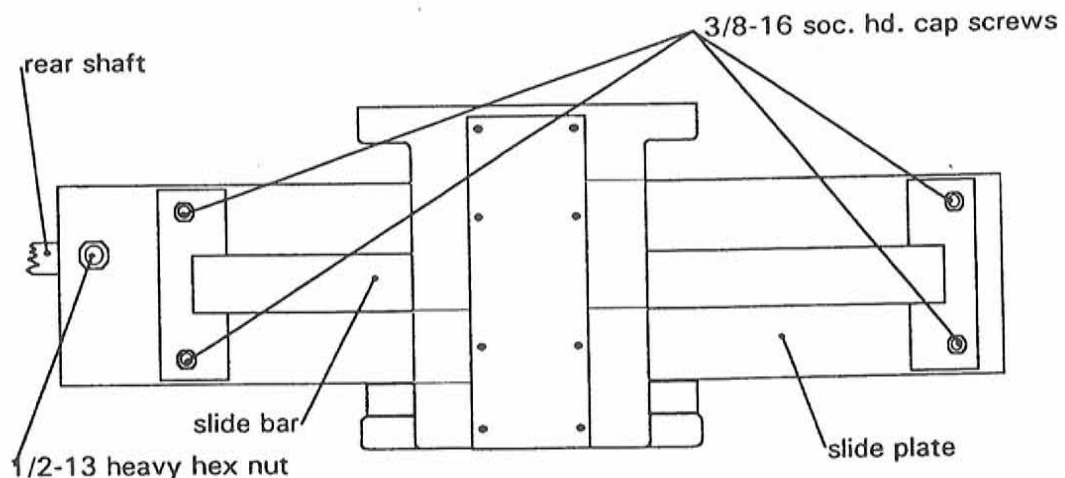

4.7 Coolant attachment

This unit has a 10 gal. tank. The flow from the tank may be shut off completely without overloading the motor. This unit also includes a removable chip and sludge collecting tray with a baffle and deflector. The coolant tank should be cleaned and refilled once every six months depending on usage.

The pump motor is supplied with a 6' long cord and plug for use with the 115v receptacle mounted at the back of the lathe.

4.8 Face plate attachment

The face plate shipped from the factory is rough turned on the part mounting surface and should be machined using a skim cut prior to first usage.

NOTE: Maximum safe operating speed for large face plates is 480 RPM.

5. MAINTENANCE INSTRUCTIONS

5.1 Drive Belts Tension Control

When changing pulleys and/or belts, loosen the motor plate clamp and lift the motor plate by means of the adjusting screw provided. With the new pulleys and/or belts in position, adjust for correct belt tension (see below) and tighten the nut on the motor plate.

For correct belt tension, use the following method:

At the center of the span, apply a force of 8 lbs. with a spring scale to deflect the belt $1/2$ ".

Check the tension frequently during the first day of operation and periodically thereafter. Keep pulleys and belts clean and free of any foreign material to ensure long life and better traction.

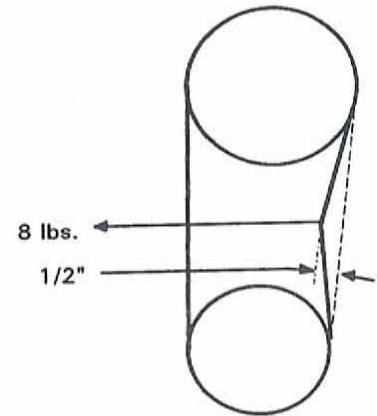

5.2 Cross slide ways

Wear in the Cross Slide Ways may be adjusted as follows:

Turn all seven $5/16$ socket set screws located on the right hand side of the Cross Slide in a clockwise direction to tighten the Gib.

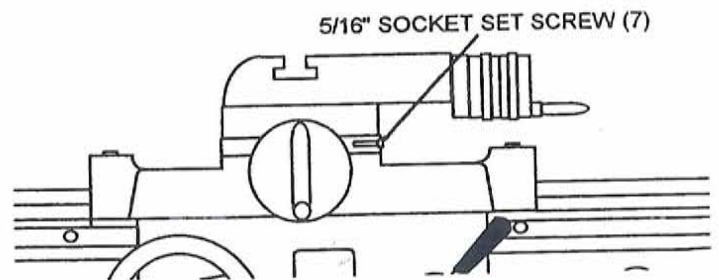

5. MAINTENANCE INSTRUCTIONS cont'd

5.3 Cross Slide Screw

Provision is made for the elimination of backlash in the Cross Slide Nut as follows.

1. Position the cross slide close to the center line of the lathe.
2. Slacken only the two 3/8" socket head cap screws. The captive spring will take up the backlash automatically.
3. Move the cross slide over full travel to be sure of an even action.
4. Tighten the two 3/8" socket head cap screws.

5.4 Compound Slide Ways

Wear in the Compound Slide Ways may be adjusted by means of the Tapered Gib Screw as follows:-

Turn the slotted head Gib Screw at the handle end in a clockwise direction to tighten.

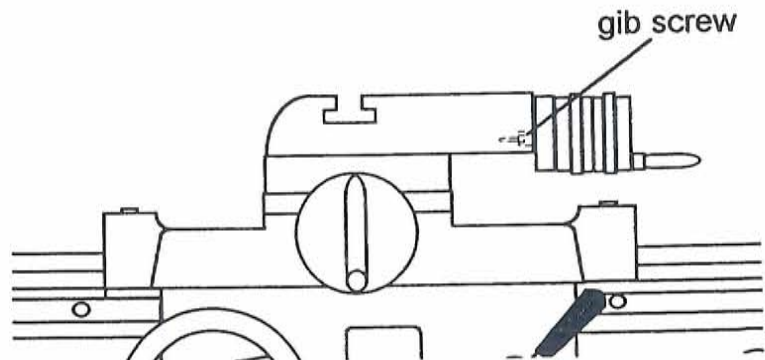

5.5 Leadscrew Shear Pin

This brass shear pin (PN/ 41192) is provided to prevent damage to the leadscrew should the carriage be allowed to come in contact with the headstock or some other obstruction which acts as a positive stop. When the stoppage takes place, the leadscrew continues to turn in the half nuts and will begin to move endwise thus shearing the pin.

The shear pin can be readily replaced by first withdrawing the leadscrew from the coupling to remove the three pieces of broken pin. It is then returned to the coupling and rotated by hand until the zero line on the leadscrew coincides with that on the coupling. A new shear pin (4 spare pins are provided with the machine) is then driven into place.

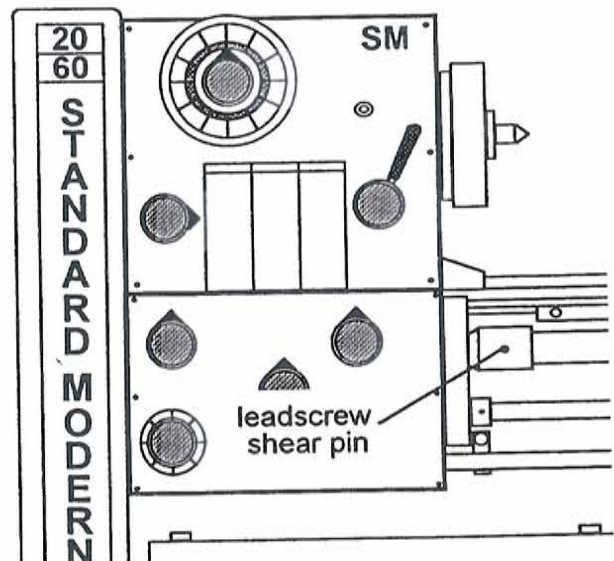

5. MAINTENANCE INSTRUCTIONS cont'd

5.6 End Gear Train Shear Key

This brass shear key (PN/ 21180) drives the top gear of the end gear train. It is provided to prevent damage to the feed gears if abnormally excessive loads are encountered.

Spare shear keys provided with the machine, are readily fitted. First remove the 48T gear, then remove the broken portions of the key from the shaft with a small square nose chisel. It is important, of course, to locate and remedy the cause of the excessive load.

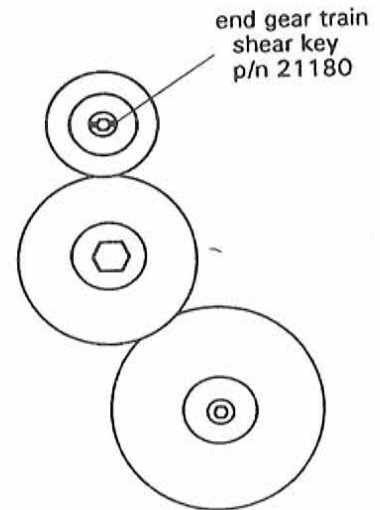

6.0 PARTS ORDERING PROCEDURE

1. Always quote the machine serial number. This is found stamped in the recessed face on top of the bed at the tailstock end.
2. Refer to the appropriate assembly and individual part numbers taken directly from the illustrations.

5. MAINTENANCE INSTRUCTIONS cont'd.5.7 Trouble Shooting Chart

TROUBLE	PROBABLE CAUSE	CORRECTION
Vibration	Loose leveling screws	Set all screws so that they bear evenly on leveling plates.
	Torn or mismatched V-belts.	Replace V-belts with matched set.
	Work or chuck out of balance operating at high spindle speeds.	Balance chuck or reduce spindle speed.
	Motor out of balance.	Contact local representative of motor manufacturer.
Chatter	Tool bit improperly ground or not on center	Regrind tool bit or adjust tool holder so that area of contact between tool bit and work is decreased. Avoid extreme negative rake.
	Tool overhang too great	Keep point of tool bit as close as possible to tool holder.
	Using improper cutting speed.	Reduce or increase spindle speed.
	Feed rate too high or too low.	Reduce or increase feed.
	Gibs of cross slide or compound rest loose.	Adjust gibs.
	Spindle bearings worn or loose.	Adjust spindle bearings.
	Work improperly supported	Adjust tailstock center. Use steady rest or follow rest for long slender shafts. Minimize tailstock barrel extension.
	Vibration	See "Vibration" trouble above.

5. MAINTENANCE INSTRUCTIONS cont'd.5.7 Trouble Shooting Chart

TROUBLE	PROBABLE CAUSE	CORRECTION
Work not turned straight	Headstock and tailstock not aligned.	Align tailstock center.
	Work improperly supported.	Use steady rest or follow rest. Reduce overhang from chuck.
	Bed not level.	Re-level bed using precision level.
Work out of round.	Work loose between centers.	Adjust tailstock center.
	Centers excessively worn. Work centers out of round.	Regrind centers. Lap work centers.
	Loose headstock spindle bearings.	Adjust headstock spindle bearings.
Cross slide or compound rest movement does not coincide with dial.	Gib setting too tight or too loose.	Adjust gibs.
	Work is too long and slender.	Use steady rest or follow rest for long slender shafts.

PART NUMBER	MANUFACTURER		QTY.	NOMENCLATURE
B63R-1	ABB)	1	DRIVE MOTOR 20HP 230-460/3/60
T75DU63	ABB)-20HP	1	REVERSING CONTACTOR WITH 120V COILS
T75DU32	ABB)	1	OVERLOAD RELAY 230V OR
)	1	OVERLOAD RELAY 460V.
B50R-1	ABB)	1	DRIVE MOTOR 15HP 230-460/3/60
T75DU52	ABB)-15HP	1	REVERSING CONTACTOR WITH 120V COILS
T75DU25	ABB)	1	OVERLOAD RELAY 230V OR
)	1	OVERLOAD RELAY 460V.
N1 20167	RALSTON		1	ENCLOSURE 20 x 16 x 7
M0350E	MARCUS		1	CONTROL TRANSFORMER 350VA 220 PRI 120 SEC
RH1B-AC120	IDEC		1	RELAY
SH1B-05	IDEC		1	RELAY BASE
CBF-BMP4R	ABB		1	E - STOP
CBK-CB01	ABB		1	CONTACT BLOCK NC
CBK-S2MK	ABB		1	SWITCH, 2 POSITION
CBK-CB10	ABB		1	CONTACT BLOCK NO
S271-K1	ABB		1	BREAKER, 1 AMP
S271-K2	ABB		1	BREAKER, 2 AMP
7596ER	BRYANT		2	RECEPTACLE
7594NP	BRYANT		2	PLUG
ZCKJ404-H7	TELEMECHANIQUE		1	FORWARD / REVERSE SWITCH
ZCK-Y11	TELEMECHANIQUE		1	ACTUATOR
511H993-40	CUTLER-HAMMER		1	BRAKE (240V) OR
511H993-41	CUTLER-HAMMER		1	BRAKE (480V)

C-85558 FIRST USED ON THE SERIAL NO 10137 EXCEPTIONS - 10080
 C-85557 " " " 10008
 C-85556 " " " 9947
 C-85555 " " " 9984

RACKS
 C-85555 FOR 2040
 C-85556 FOR 2060
 C-85557 FOR 2080 (2 REQ'D)
 C-85558 FOR 20/20 (2 REQ'D) & 20/20 (2 REQ'D)

SOC HD CAP SCR
 5/16-18 X 1 1/4 LG
 (QUANTITIES TO SUIT ABOVE RACKS)

DOWEL PIN
 5/16 DIA X 2 LG - 2 REQ'D

SOC HD CAP SCREW
 5/16-18 X 1 1/4 LG - 4 REQ'D

LEADSCREW (1 1/4 DIA - 4 TPL ACME)
 C-85085 FOR 2060
 C-85089 FOR 2080
 C-85101 FOR 20/20

FEEDSHAFT
 B-85086 FOR 2060
 B-85090 FOR 2080
 B-85100 FOR 20/20

TRIP CAM
 B-84592

ROLL PIN
 5/16 DIA X 1 1/2

CAM ROLLER
 A-32713

CAM ROLLER SUPPORT
 A-32711

DOWEL 1/4 DIA X 1/2

SOC HD CAP SCR
 #10-32 UNF X 5/8 LG
 (3) REQ'D

MOTOR CONTROL SHAFT
 B-84774 FOR 2060
 B-85091 FOR 2080
 B-85120 FOR 20/20

LEADSCREW REVERSE CONTROL ROD
 B-84775 FOR 2060 (109.25 LG)
 B-85092 FOR 2080 (129.25 LG)
 B-85099 FOR 20/20 (169.25 LG)

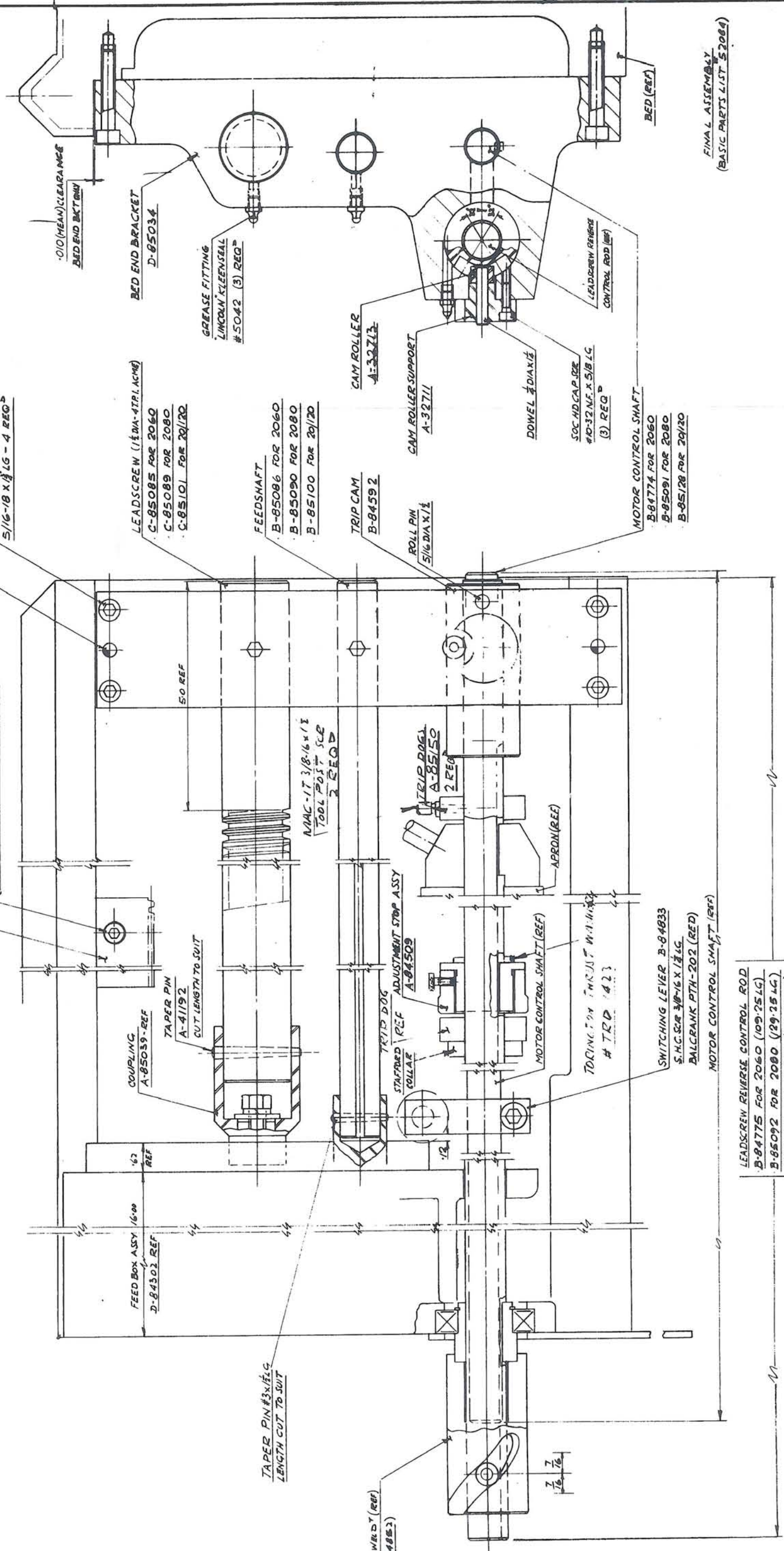

0.010 (MEAN) CLEARANCE
 BED END BKT BRN

BED END BRACKET
 D-85034

GREASE FITTING
 LINCOLN KLEENSEAL
 #5042 (3) REQ'D

LEADSCREW REVERSE
 CONTROL ROD (REF)

BED (REF)

FINA L ASSEMBLY
 (BASIC PARTS LIST 52064)

STANDARD-MORRIS TOOL COMPANY LIMITED		TORONTO, CANADA	
ITEM NO.	QTY	ITEM NO.	QTY
B			
C			
D			
E			
F			
G			
H			
I			
J			
K			
L			
M			
N			
O			
P			
Q			
R			
S			
T			
U			
V			
W			
X			
Y			
Z			

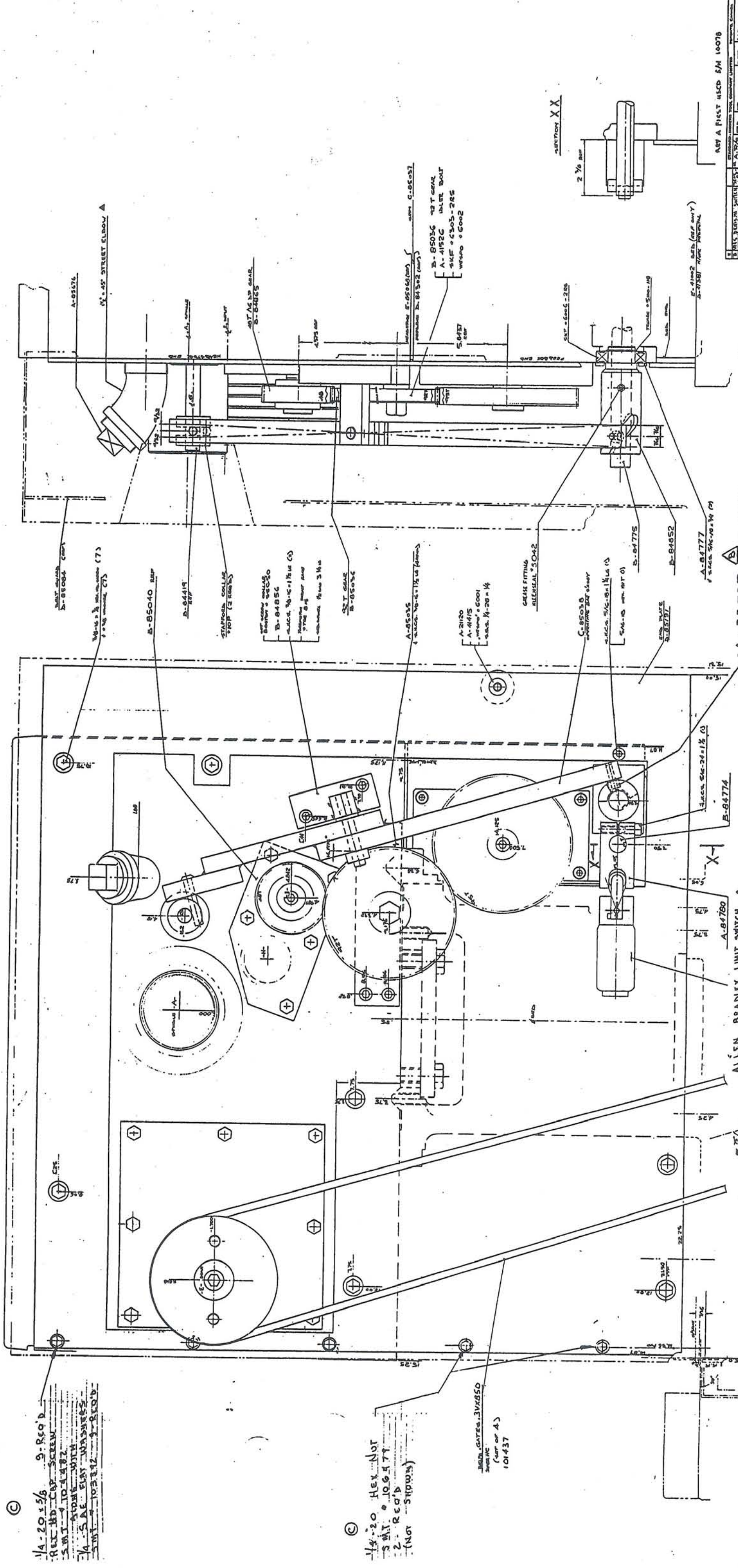

- 1/4-20 x 5/8 2-REG'D
- REG HD CAP SCREW
- SWT 106477
- ADJUST WITH
- 1/4-5 AE EASY ADJUST
- SWT 106477 2-REG'D

- 1/4-20 Hex Nut
- SWT 106477
- 2-REG'D
- (NOT SHOWN)

REG'D GATES 316SS50
SWT 106437
(SEE A)

ALLEN BRADLEY LIMIT SWITCH
8021-NPTP SWT 102552

A-85107

SECTION XX

REV	DATE	BY	CHKD	DESCRIPTION
1	10/25/52
2
3
4

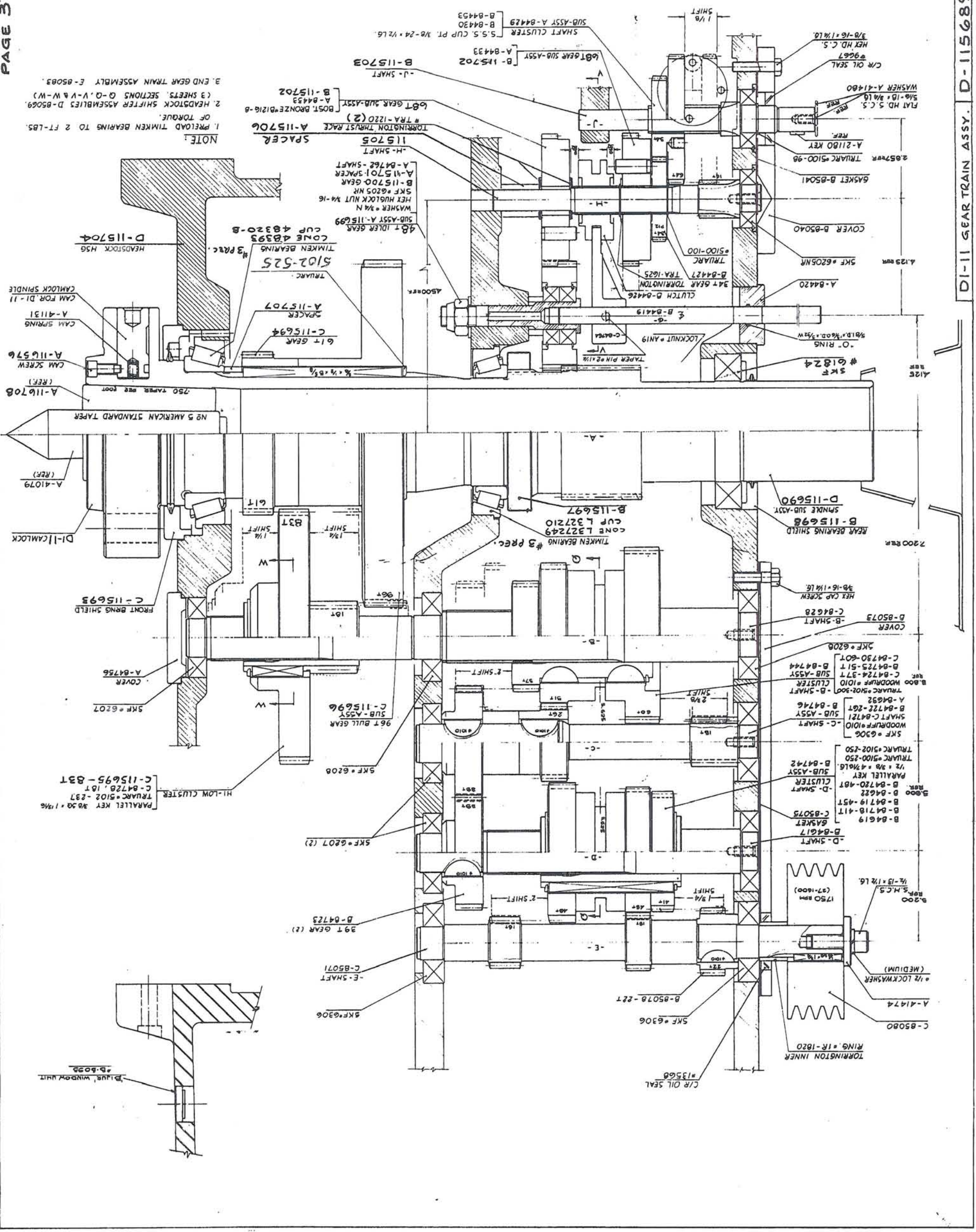

NOTE:
 1. PRELOAD TIMKEN BEARING TO 2 FT.-LBS. OF TORQUE.
 2. HEADSTOCK SHIFTER ASSEMBLIES D-85069, (3 SHEETS, SECTIONS Q-Q, V-V & W-W)
 3. END GEAR TRAIN ASSEMBLY E-85083.

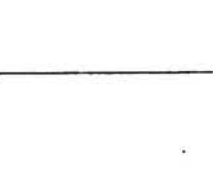
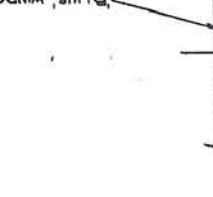
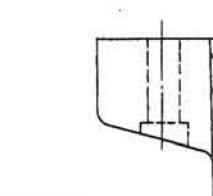
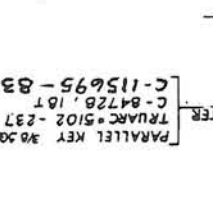
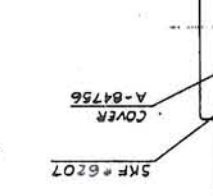
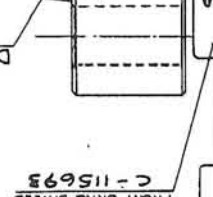
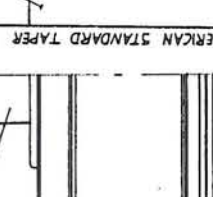
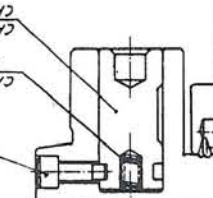
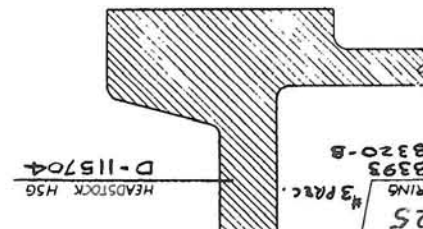

SECTION W W
(ON ANG F-85068)

X 41

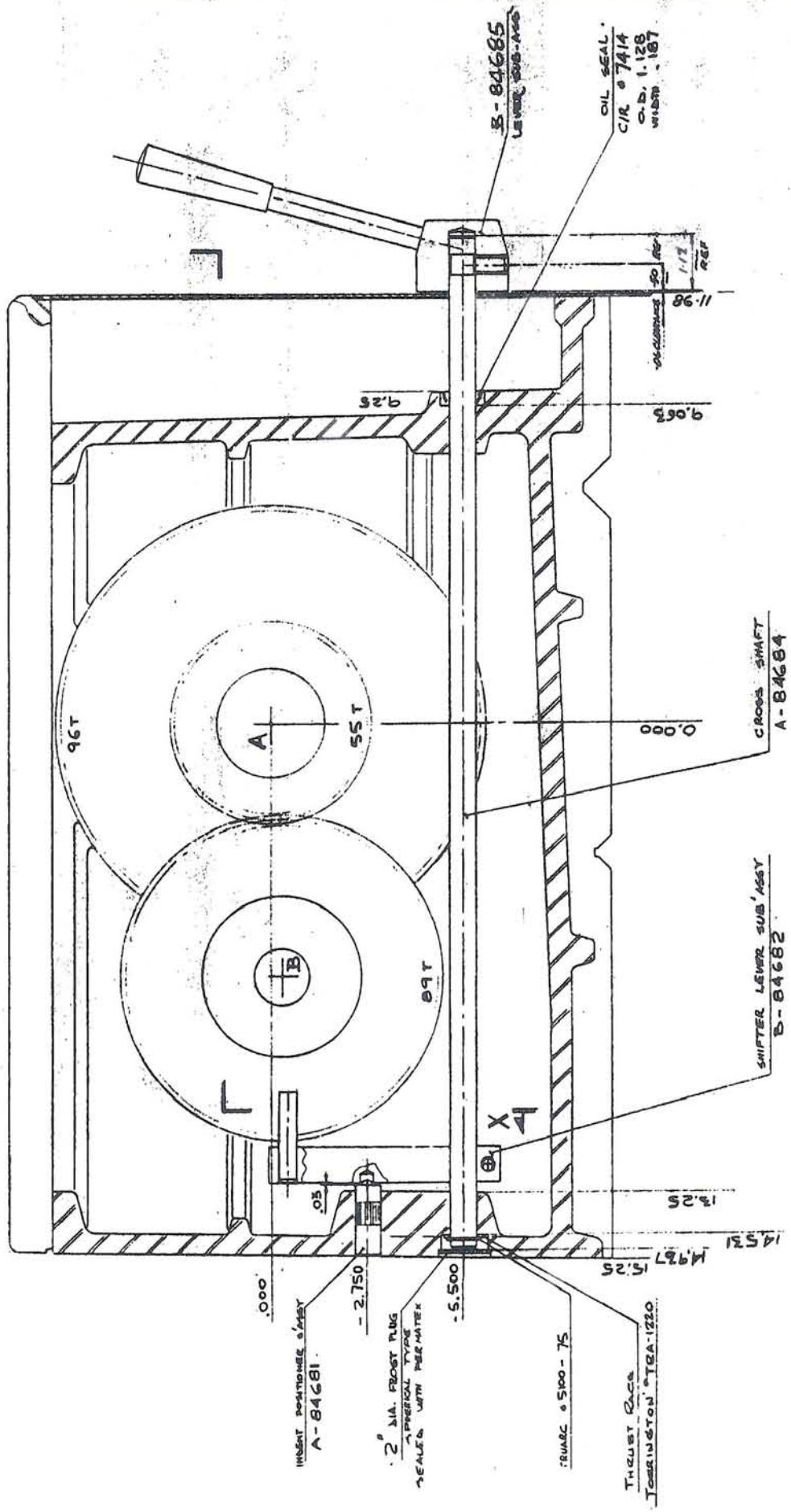
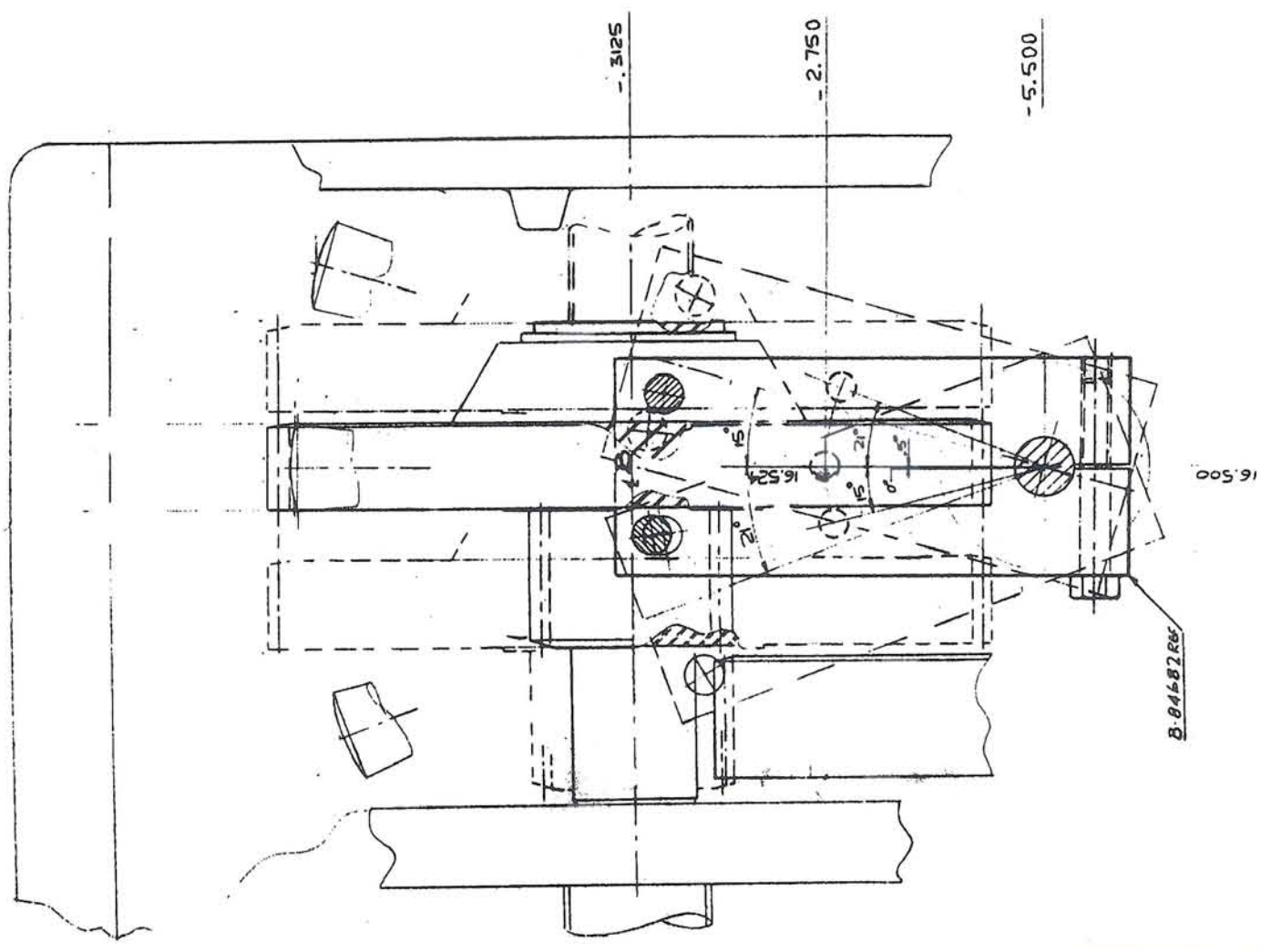

SECTION XX
SCALE: FULL SIZE

ITEMS REQUIRED BUT NOT SHOWN		REMARKS
3	SHIFT LEVER SUB-ASSY	
4	CAP SCREW 5/16-18 x 3/4	FOR PART NO B-84734
1	OIL SEAL	CIR # C-84713
2	WRENCH	FOR PART NO C-84712
1	WRENCH	
1	WRENCH	

1	STANDARD-MODERN TOOL COMPANY LIMITED	TORONTO, CANADA
2	STANDARD-MODERN TOOL COMPANY LIMITED	TORONTO, CANADA
3	STANDARD-MODERN TOOL COMPANY LIMITED	TORONTO, CANADA
4	STANDARD-MODERN TOOL COMPANY LIMITED	TORONTO, CANADA
5	STANDARD-MODERN TOOL COMPANY LIMITED	TORONTO, CANADA
6	STANDARD-MODERN TOOL COMPANY LIMITED	TORONTO, CANADA
7	STANDARD-MODERN TOOL COMPANY LIMITED	TORONTO, CANADA
8	STANDARD-MODERN TOOL COMPANY LIMITED	TORONTO, CANADA
9	STANDARD-MODERN TOOL COMPANY LIMITED	TORONTO, CANADA
10	STANDARD-MODERN TOOL COMPANY LIMITED	TORONTO, CANADA

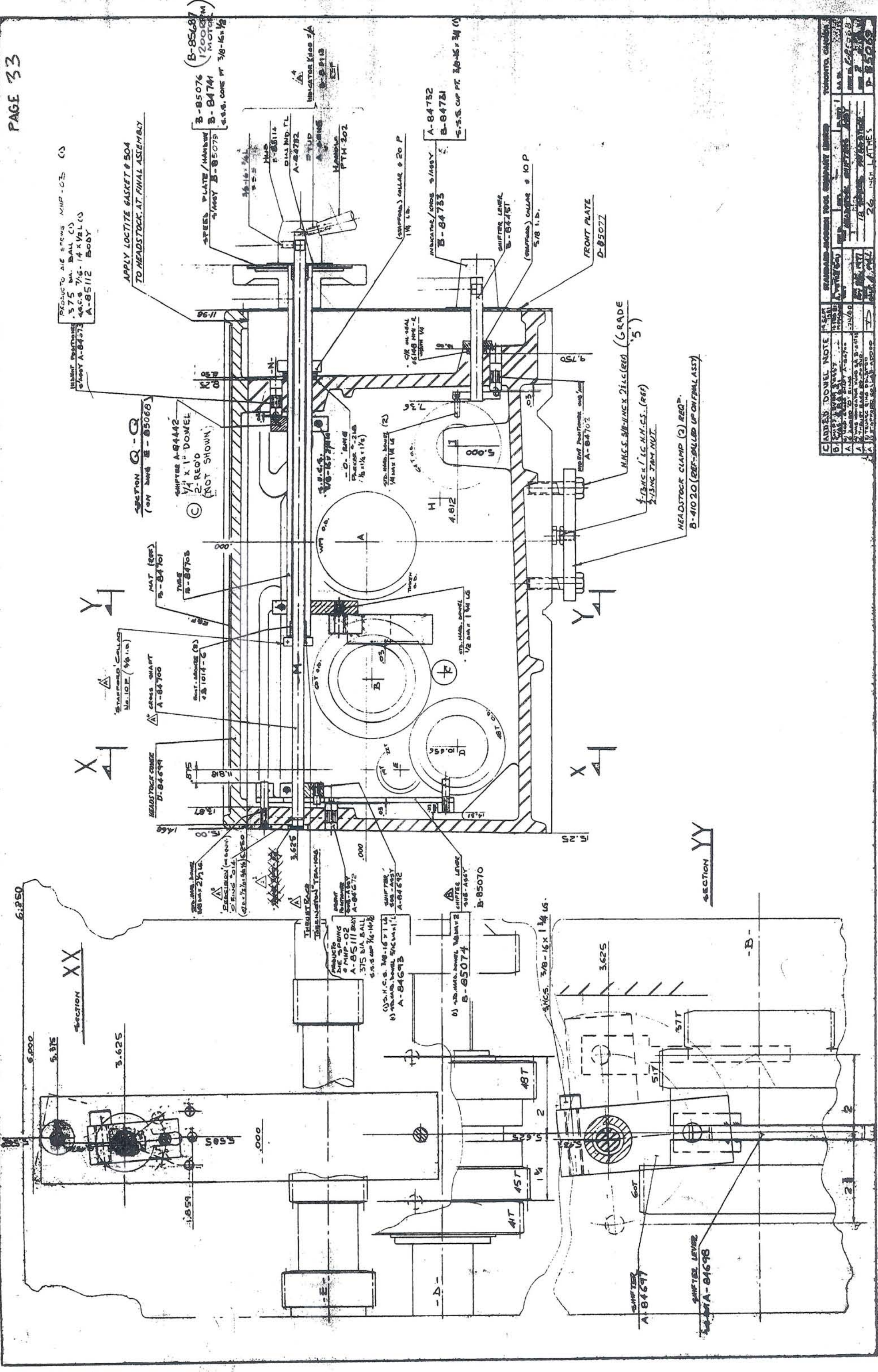

PRODUCT TO DIE FROM MHP-02 (C)
 .375 DIA. BALL (C)
 400.8 7/16-14 X 1/2 (C)
 A-85112 Body

APPLY LOCTITE GASKET # 504
 TO HEADSTOCK AT FINAL ASSEMBLY

B-85076 (B-85076)
 B-84741 (B-84741)
 4.5.5. CAP PT 3/8-16 X 1/2

A-84752
 B-84751
 4.5.5. CAP PT 3/8-16 X 1/2 (C)

SECTION Q-Q
 (ON BUSH B-85068)

SHIFTER A-84442
 1/4" X 1" DOMEL
 2-REQD
 (NOT SHOWN)

NUTS 3/8-16 X 2 1/2 (REQD) (GRADE 5)

HEADSTOCK CLAMP (3) REQD
 B-41020 (REF-BULLED UP ON FINAL ASST)

SECTION XX

SECTION YY

ADDRESS	DATE	REVISION	BY	CHKD	APP'D	DESCRIPTION
1	11/10/60	1	J. J.
2	11/10/60	2	J. J.
3	11/10/60	3	J. J.
4	11/10/60	4	J. J.
5	11/10/60	5	J. J.

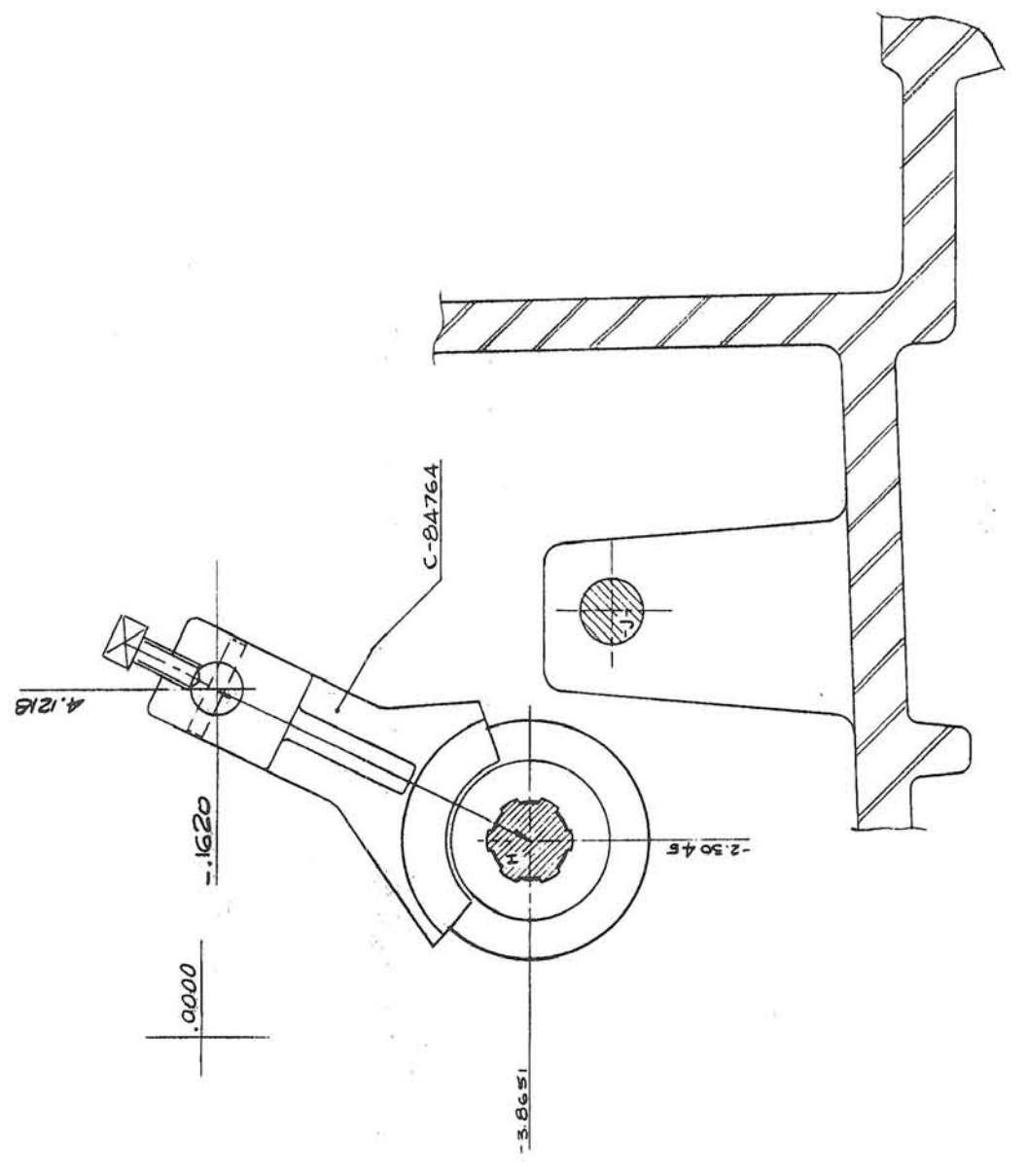
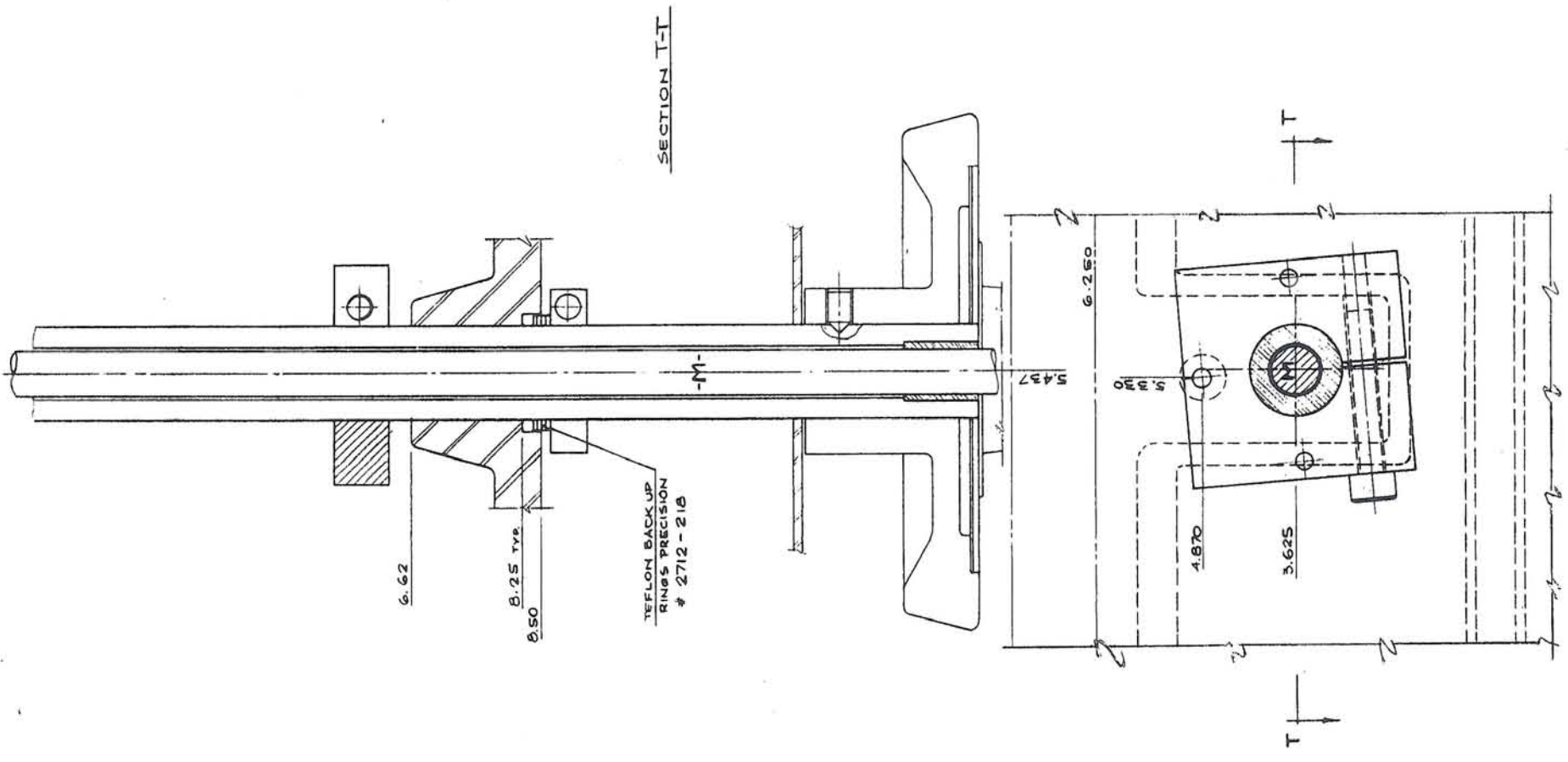

E	STANDARD-HOBBS TOOL COMPANY LIMITED		TORONTO, CANADA
D	REV.	DATE	BY
C	1		
B	HEADSTOCK SHIFTERS & SKV J&S STEEL HEADSTOCK		
A	MAY 25-78	26 21 1788	E-85068 E-85069
	QUANTITY	SCALE	
	1	FULL	

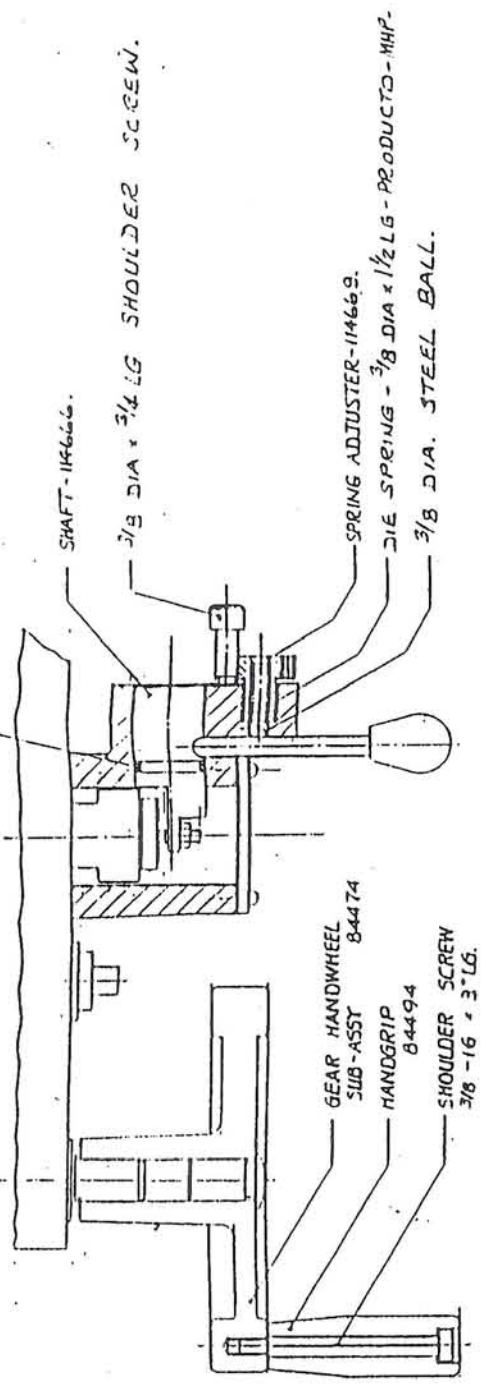

SECTION B-B

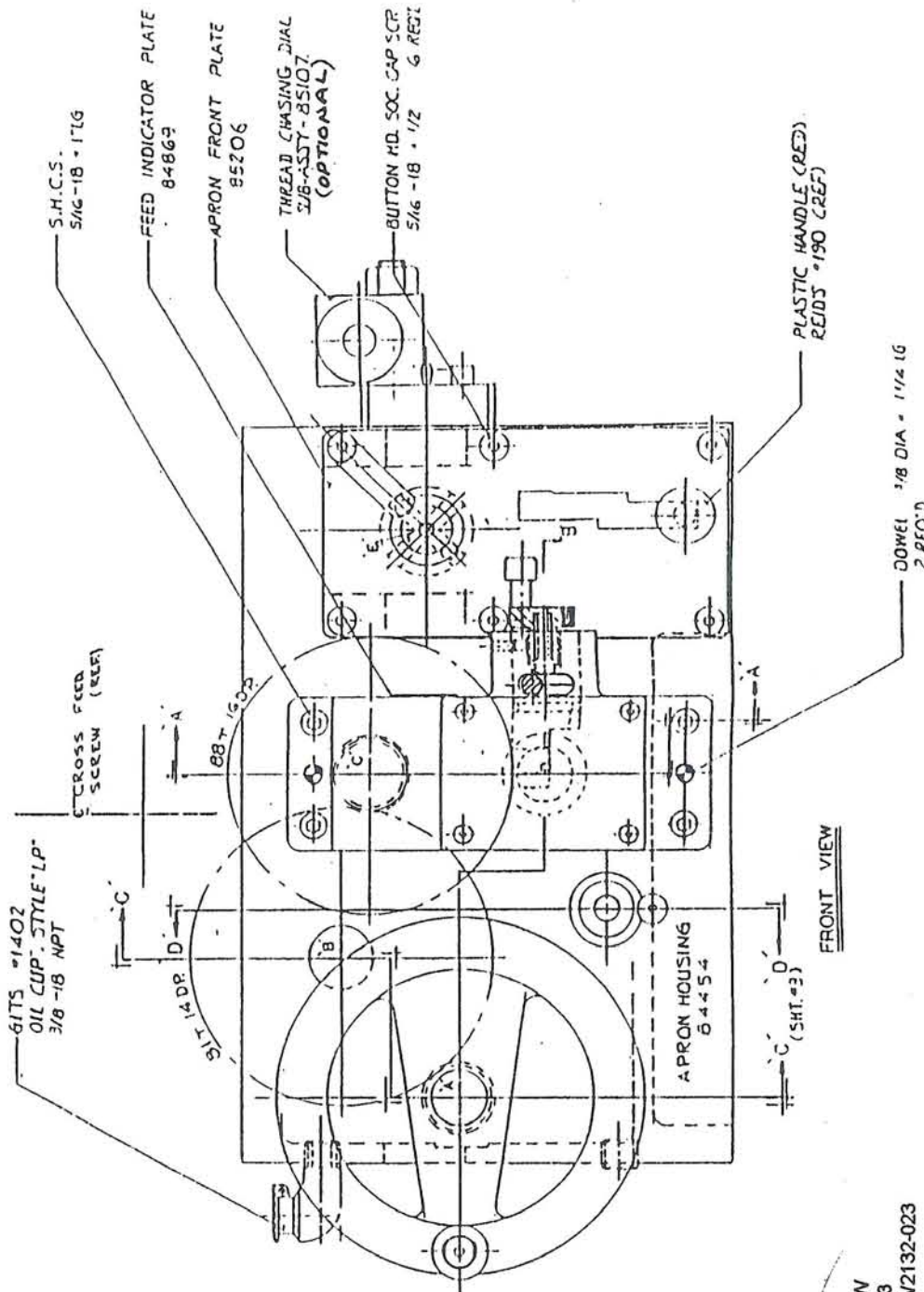

FRONT VIEW

- SOC. SET SCREW 3/8 - 24 x 5/8 LG. (CUP PT.)
- WALLACE BARNES SPRING #C-0300 -038 -0810
- 5/16 DIA HDN STEEL BALL
- REIDS PLASTIC BALL (BK) #B-15.
- HANDLE BAR-114668.
- REIDS OVAL PLASTIC KNOB (RED) #DCA-2.

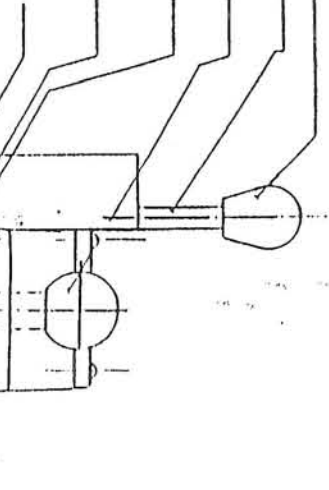

- SHAFT - SEE NOTE 85630
- GEAR SUB-ASSY 84479
- BOSTON-BRONZ BRG NO 34822-81012-5 2 REQ'D
- TORRINGTON WASHER #TRA-1018 2 REQ'D
- TRUARC RETAINER #S133-G2 2 REQ'D

APRON HOUSING - 84454.

- CONTROL BOX HOUSING-114661.
- #10-NC-1/2 LG RD. #D. SOC. SCREW (4 REQ'D)
- CONTROL BOX COVER-114671.

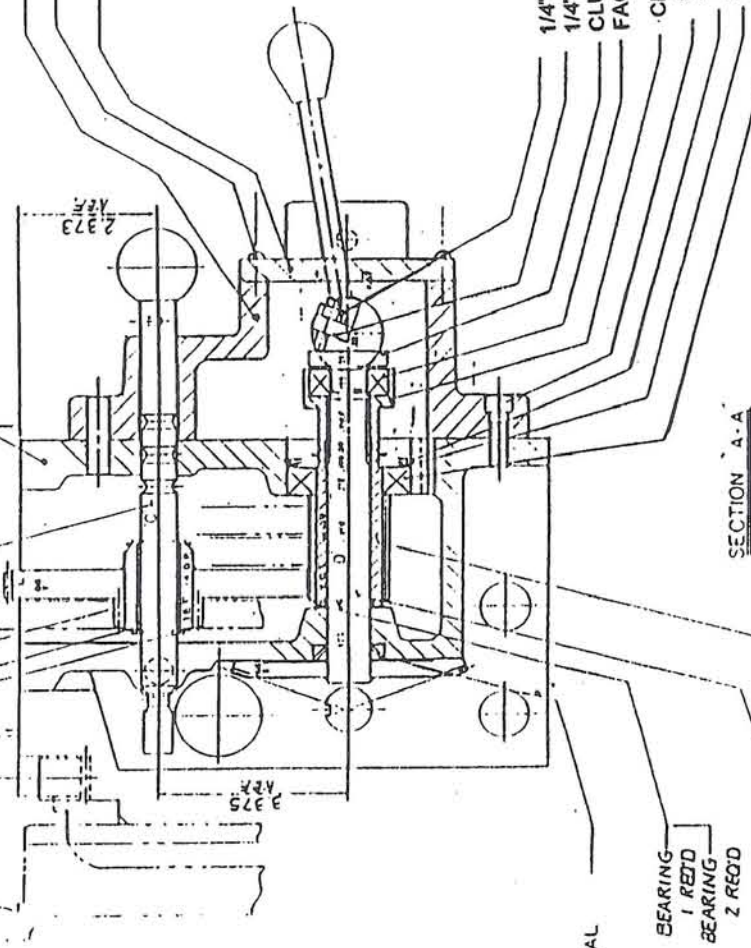

SECTION A-A

- C/R OIL SEAL NO 7440
- TORRINGTON BEARING #NTA-1120 1 REQ'D
- TORRINGTON BEARING #TRA-1120 2 REQ'D
- BEVEL GEAR SUB-ASSY 114662
- CLUTCH GEAR 114663

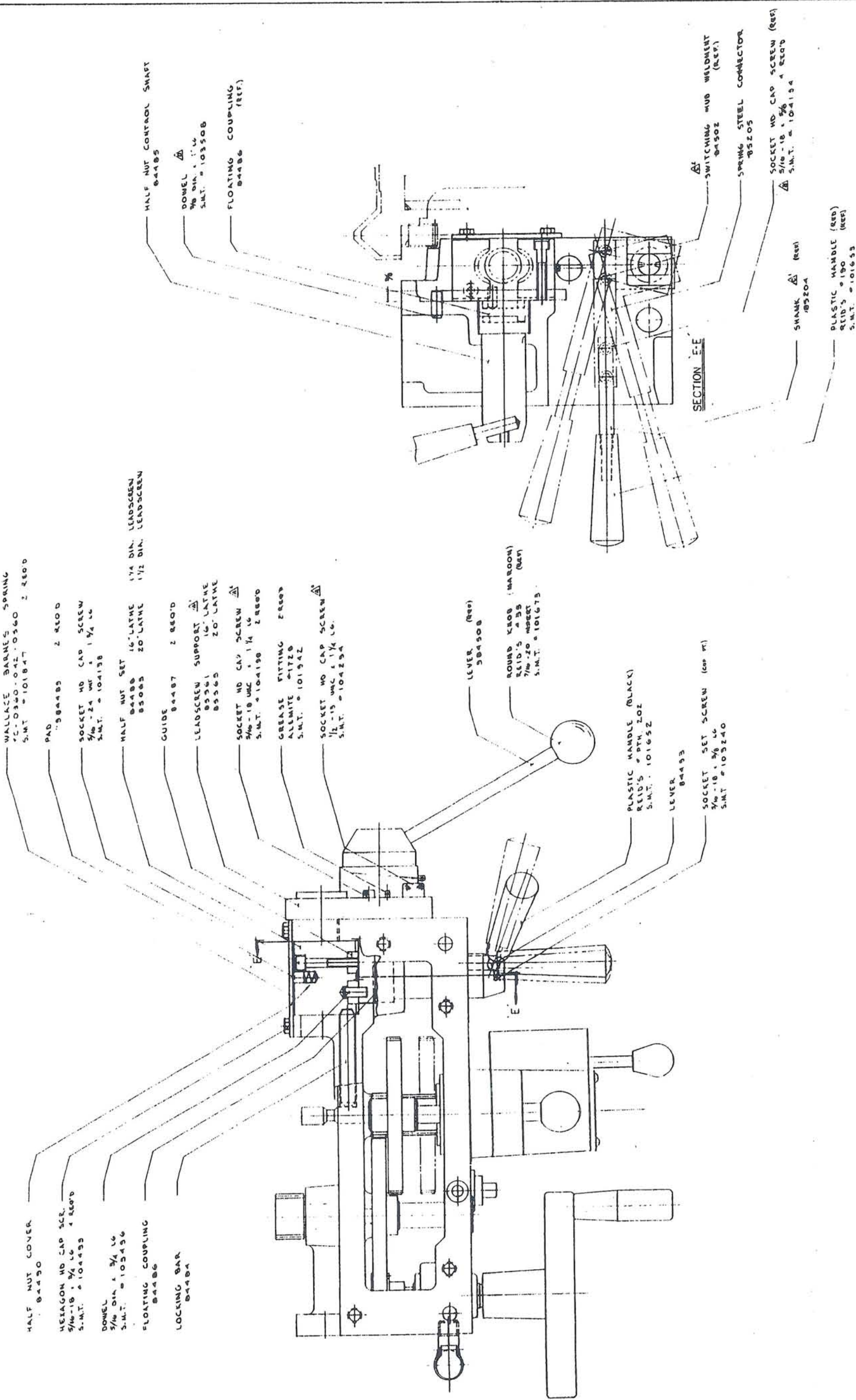

- WALLACE BARNES SPRING
72-0340-042-0560
S.M.T. # 101847 2 REQD
- PAD
58485 2 REQD
- SOCKET HD CAP SCREW
5/16-24 UNC x 1 1/2 LG
S.M.T. # 104138
- HALF NUT SET
84488 16 LATHE 1 1/4 DIA. LEADSCREEN
85085 20 LATHE 1 1/2 DIA. LEADSCREEN
- GUIDE
84487 2 REQD
- LEADSCREW SUPPORT
85561 16 LATHE
85565 20 LATHE
- SOCKET HD CAP SCREW
5/16-18 UNC x 1 1/4 LG
S.M.T. # 104138 2 REQD
- GREASE FITTING
ALLWHITE #1720
S.M.T. # 101942
- SOCKET HD CAP SCREW
1/2-13 UNC x 1 1/4 LG
S.M.T. # 104234

- HALF NUT COVER
84490
- HEXAGON HD CAP SCR.
5/16-18 x 3/4 LG 4 REQD
S.M.T. # 104433
- DOWEL
5/16 DIA. x 3/4 LG
S.M.T. # 103456
- FLOATING COUPLING
84486
- LOCKING BAR
84484

- LEVER (REF)
384508
- ROUND KNOB (MAROON)
REID'S # 35
7/16-20 SOCKET
S.M.T. # 101673
- PLASTIC HANDLE (BLACK)
REID'S # PTH 202
S.M.T. # 101652
- LEVER
84493
- SOCKET SET SCREW (REF)
5/16-18 x 3/8 LG
S.M.T. # 103240

- HALF NUT CONTROL SHAFT
84485
- DOWEL
5/16 DIA. x 1 1/4
S.M.T. # 103508
- FLOATING COUPLING (REF)
84486
- SWITCHING HUB WELDMENT (REF)
84502
- SPRING STEEL CONNECTOR
85205
- SOCKET HD CAP SCREW (REF)
5/16-18 x 3/8 LG 4 REQD
S.M.T. # 104134
- SHANK (REF)
85204
- PLASTIC HANDLE (REF)
REID'S # 190
S.M.T. # 101653

SECTION E-E

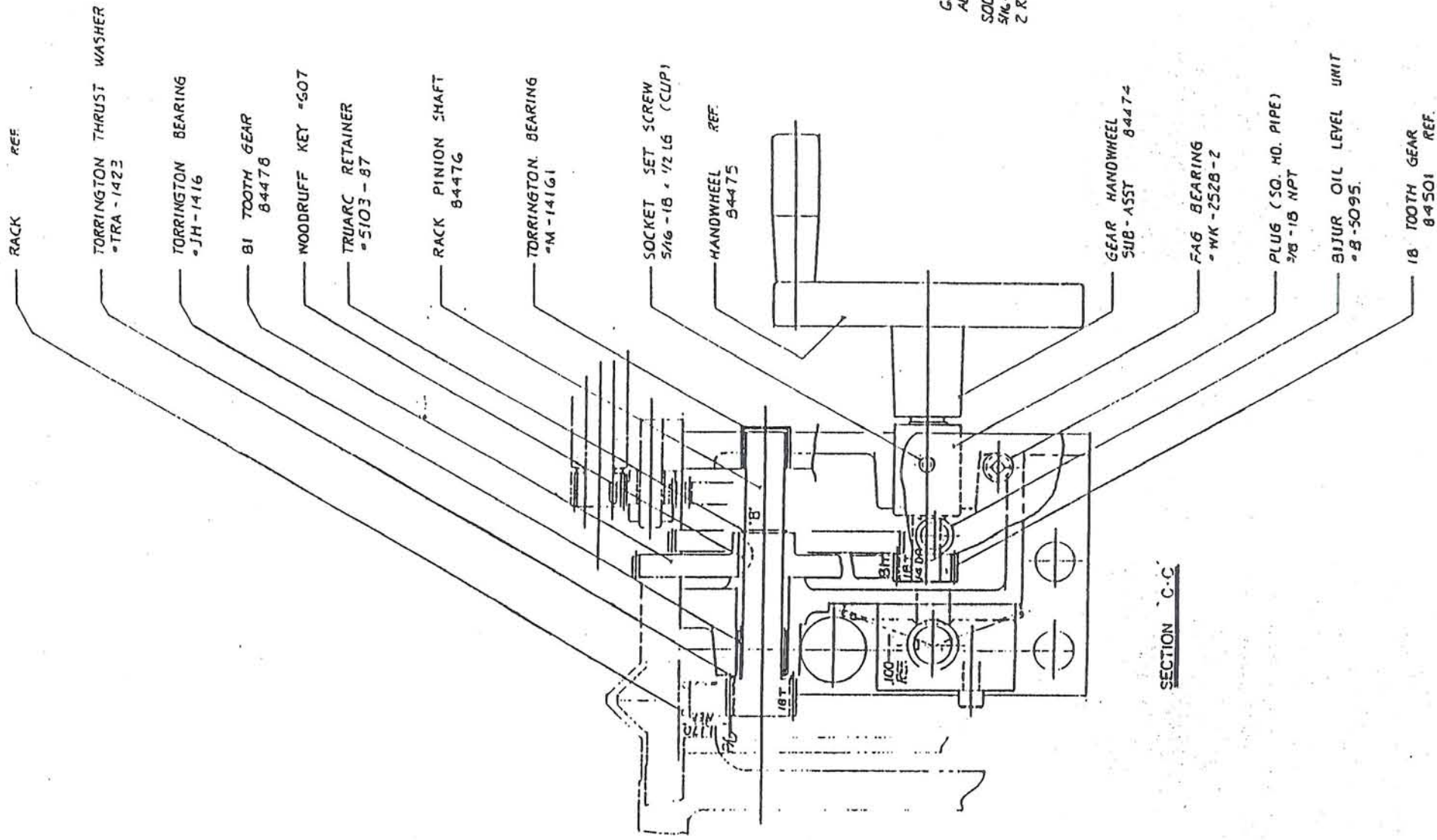

SECTION C-C

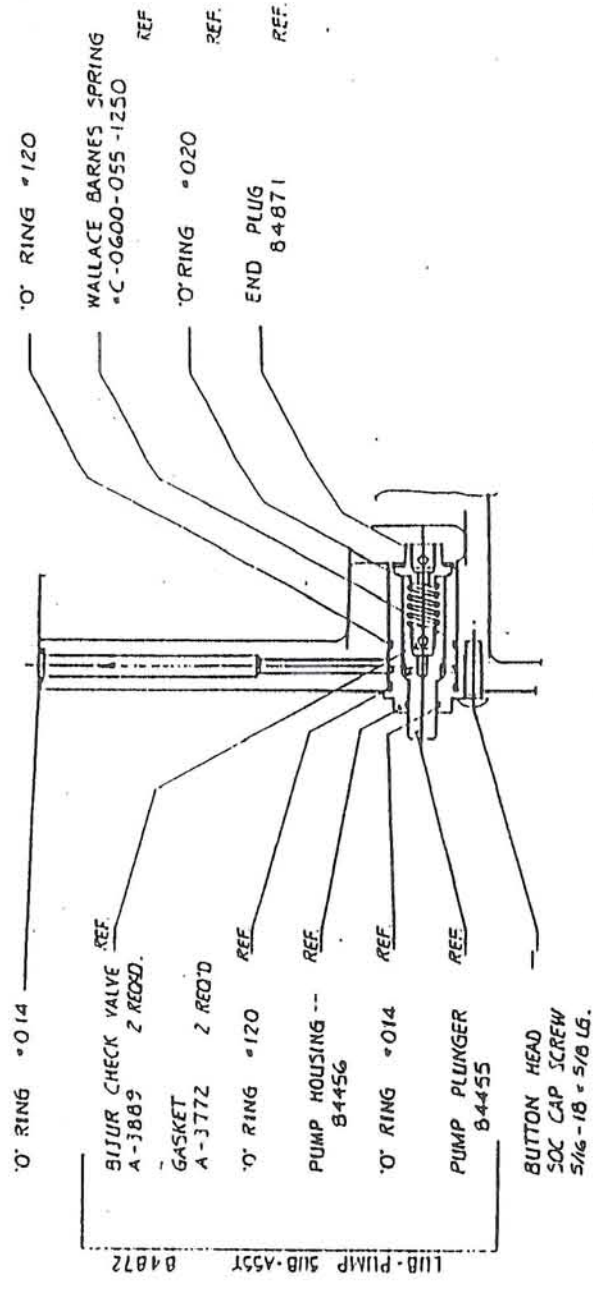

SCRAP SECTION D-D
(SHEET #1) REF.

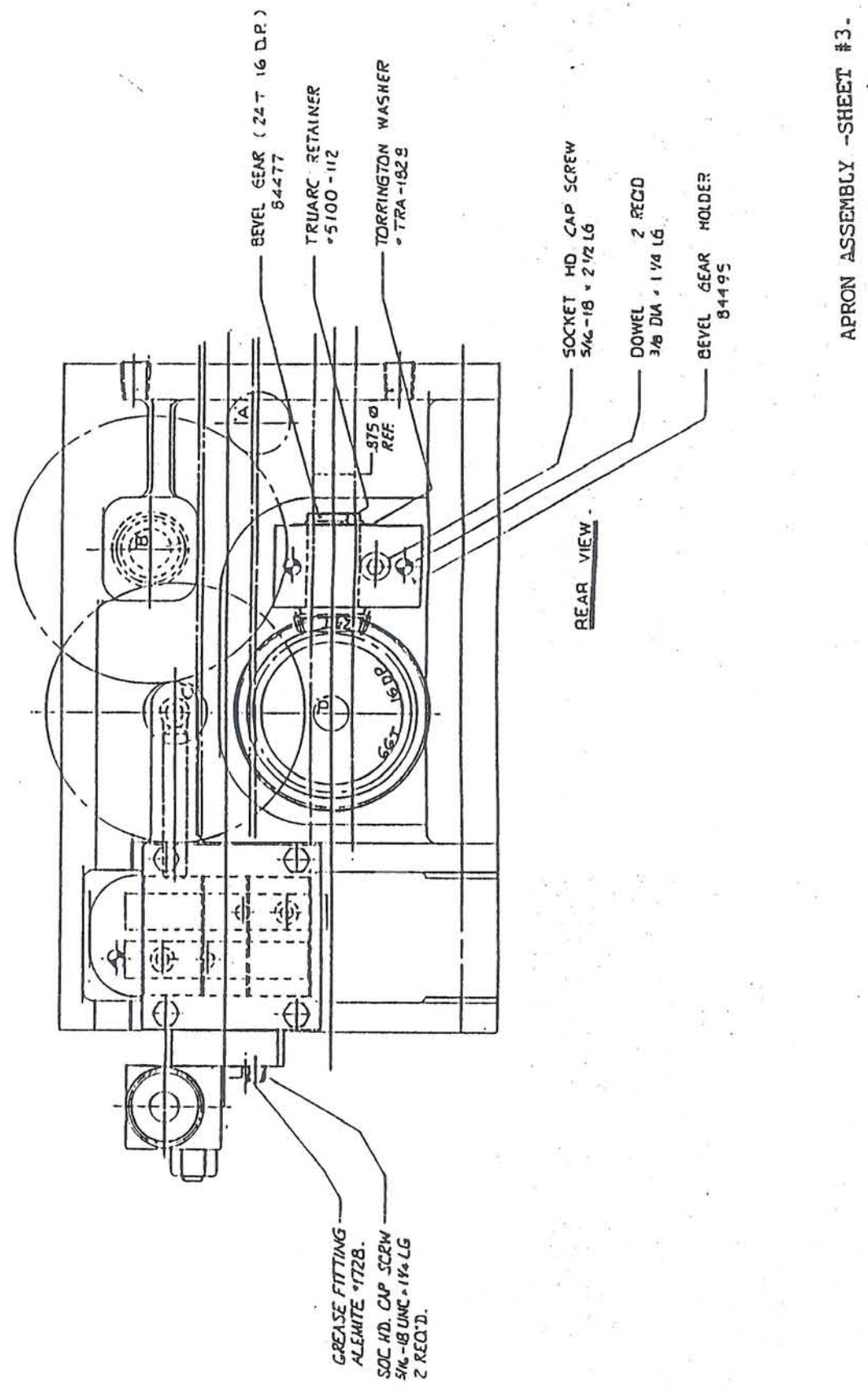

REAR VIEW

PKT NO	QTY	PKT NO	QTY
1	1	17	1
2	1	18	1
3	1	19	1
4	1	20	1
5	1	21	1
6	1	22	1
7	1	23	1
8	1	24	1
9	1	25	1
10	1	26	1
11	1	27	1
12	1	28	1
13	1	29	1
14	1	30	1
15	1	31	1
16	1	32	1

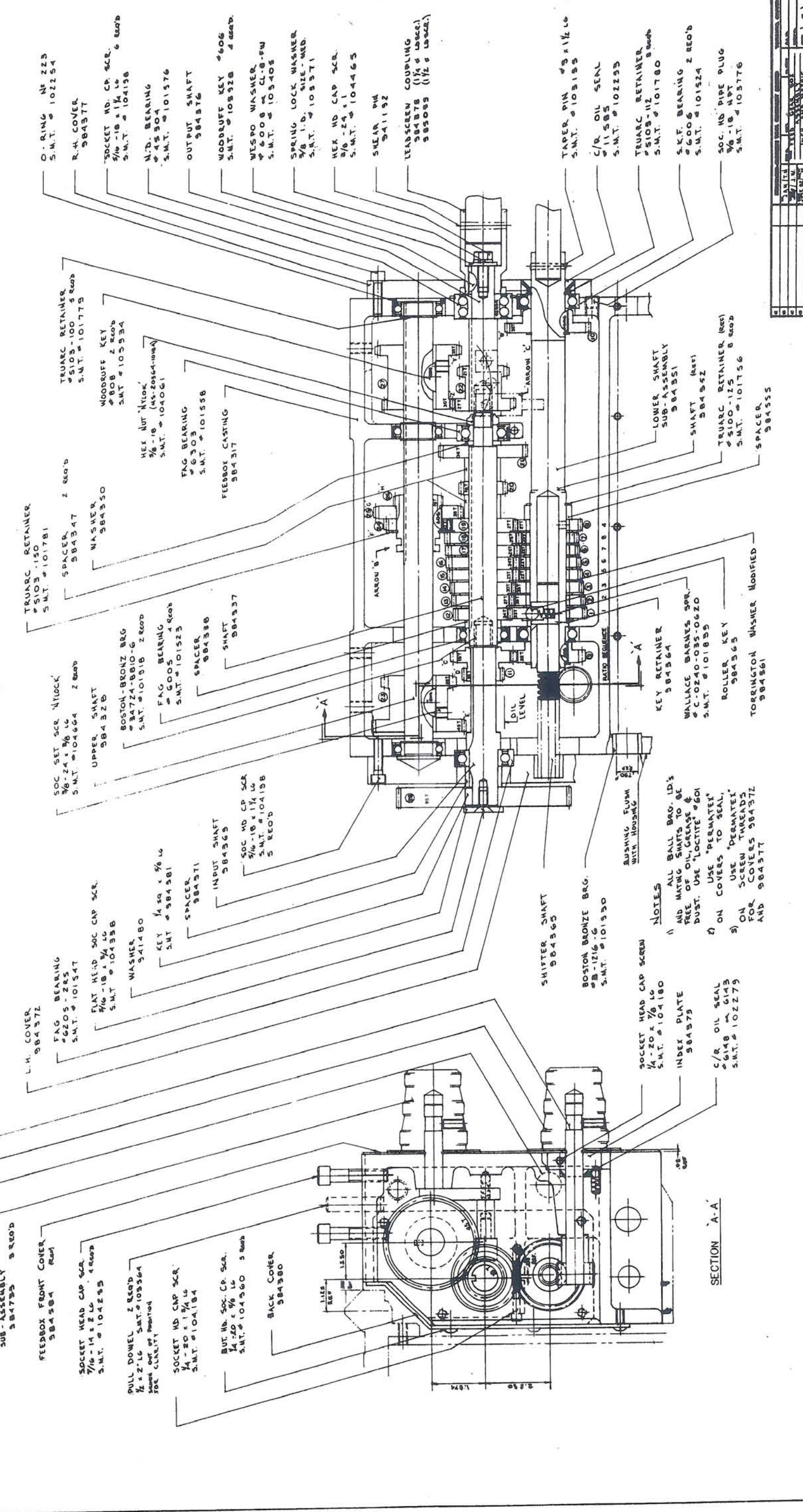
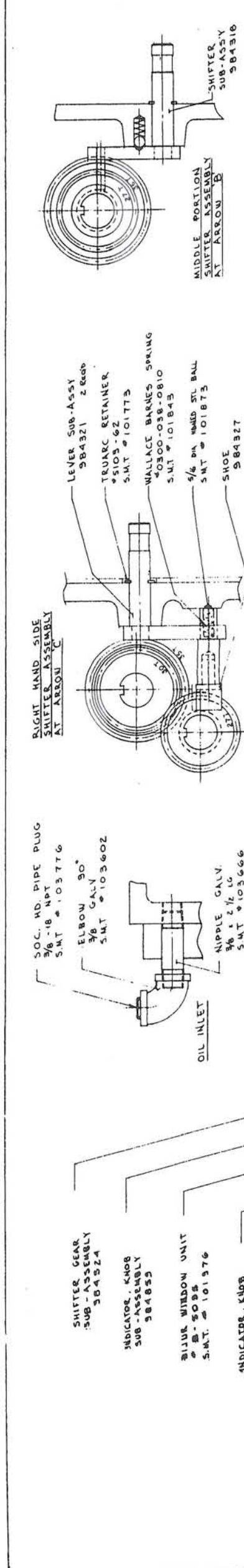

- D-RING NR 223 S.M.T. # 102254
- R.H. COVER 984377
- SOCKET HD. CP. SCR. 5/16-18 x 1 1/4 LG 6 REOD S.M.T. # 104196
- N.D. BEARING 45 904 S.M.T. # 101576
- OUTPUT SHAFT 984376
- WOODRUFF KEY #606 S.M.T. # 103928 4 REOD
- WESPO WASHER #608 CL-B-FW S.M.T. # 105405
- SPRING LOCK WASHER 3/8 I.D. SIZE-MED S.M.T. # 103971
- HEX HD CAP SCR. 3/8-24 x 1 S.M.T. # 104465
- SHEAR PIN 941192
- LEADSCREEN COUPLING 984378 (1/4 & 1/2 LG) 985089 (1/2 & 1/4 LG)
- TAPER PIN #3 x 1 1/2 LG S.M.T. # 103189
- C/R OIL SEAL #11585 S.M.T. # 102299
- TRUARC RETAINER #5103-112 8 REOD S.M.T. # 101780
- SKF BEARING 2 REOD'S #6006 S.M.T. # 101524
- SOC. HD PIPE PLUG 3/8-18 NPT S.M.T. # 103776
- TRUARC RETAINER #5103-100 5 REOD S.M.T. # 101779
- WOODRUFF KEY #808 2 REOD'S S.M.T. # 105934
- HEX NUT #100K 3/8-18 (MS-20564-1088) S.M.T. # 104061
- FRAG BEARING #6303 S.M.T. # 101558
- FEEDBOX CASTING 984317
- TRUARC RETAINER #5103-150 S.M.T. # 101781
- SPACER 984347
- MASKER 984350
- LOWER SHAFT SUB-ASSEMBLY 984351
- SHAFT 984352
- TRUARC RETAINER (REF) #5100-125 8 REOD S.M.T. # 101756
- SPACER 984355
- LEVER SUB-ASSY 984321 2 REOD'S
- TRUARC RETAINER #5103-62 S.M.T. # 101775
- WALLACE BARNES SPRING #0300-038-0810 S.M.T. # 101845
- 5/8 DIA WARD ST BALL S.M.T. # 101875
- SHOE 984327
- TRUARC RETAINER #5103-101 S.M.T. # 101781
- SPACER 984347
- MASKER 984350
- BOSTON-BRONZ BRG #34724-8810-6 S.M.T. # 101918 2 REOD'S
- FRAG BEARING #6005 4 REOD'S S.M.T. # 101523
- SPACER 984338
- SHAFT 984337
- KEY RETAINER 984364
- WALLACE BARNES SPR. #C-0240-035-0620 S.M.T. # 101839
- ROLLER KEY 984365
- TORRINGTON WASHER MODIFIED 984361
- SOC SET SCR #100K 3/8-24 x 3/8 LG S.M.T. # 104664 2 REOD'S
- UPPER SHAFT 984328
- BOSTON-BRONZ BRG #34724-8810-6 S.M.T. # 101918 2 REOD'S
- FRAG BEARING #6005 4 REOD'S S.M.T. # 101523
- SPACER 984338
- SHAFT 984337
- KEY RETAINER 984364
- WALLACE BARNES SPR. #C-0240-035-0620 S.M.T. # 101839
- ROLLER KEY 984365
- TORRINGTON WASHER MODIFIED 984361
- FLAT HEAD SOC CAP SCR. 5/16-18 x 3/4 LG S.M.T. # 104338
- WASHER 941480
- KEY 1/4 SQ x 3/8 LG S.M.T. # 984581
- SPACER 984371
- INPUT SHAFT 984369
- SOC HD CP SCR. 5/16-18 x 1 1/4 LG 5 REOD S.M.T. # 104196
- SHIFTER SHAFT 984365
- BOSTON BRONZE BRG. #B-1216-G S.M.T. # 101930
- KEY RETAINER 984364
- WALLACE BARNES SPR. #C-0240-035-0620 S.M.T. # 101839
- ROLLER KEY 984365
- TORRINGTON WASHER MODIFIED 984361

NOTES

- 1) ALL BALL BRG. IDs AND MATING SHAFTS TO BE FREE OF OIL GREASE & DUST. USE "LOCTITE" #601
- 2) ON COVERS TO SEAL, USE "PERMATEX"
- 3) ON SCREEN THREADS FOR COVERS 984372 AND 984377

SECTION A-A

REV			
1			
2			
3			
4			
5			
6			
7			
8			
9			
10			
11			
12			
13			
14			
15			
16			

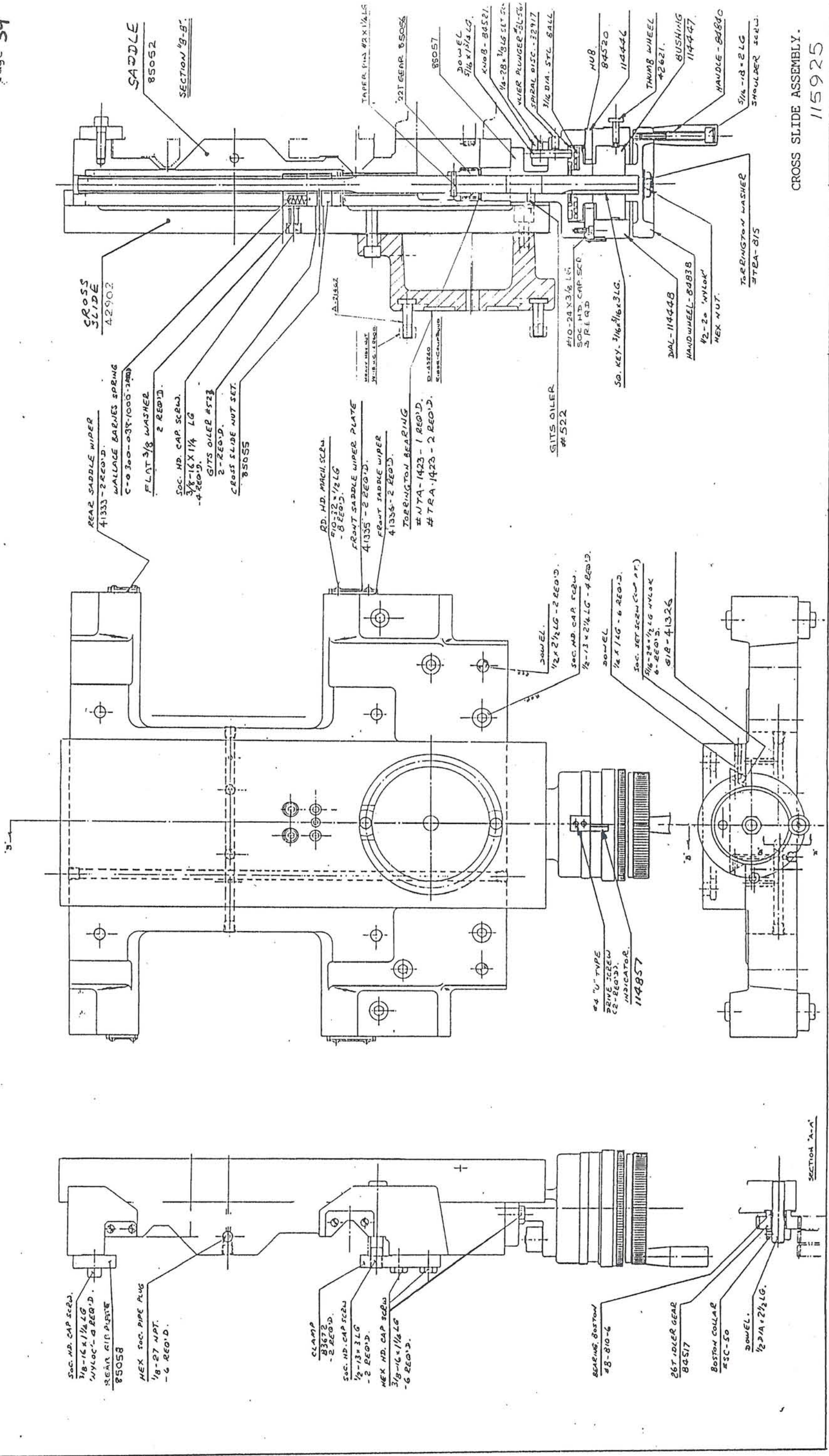

CROSS SLIDE ASSEMBLY. 115925

SECTION "A-A"

SCRAP SECTION XX

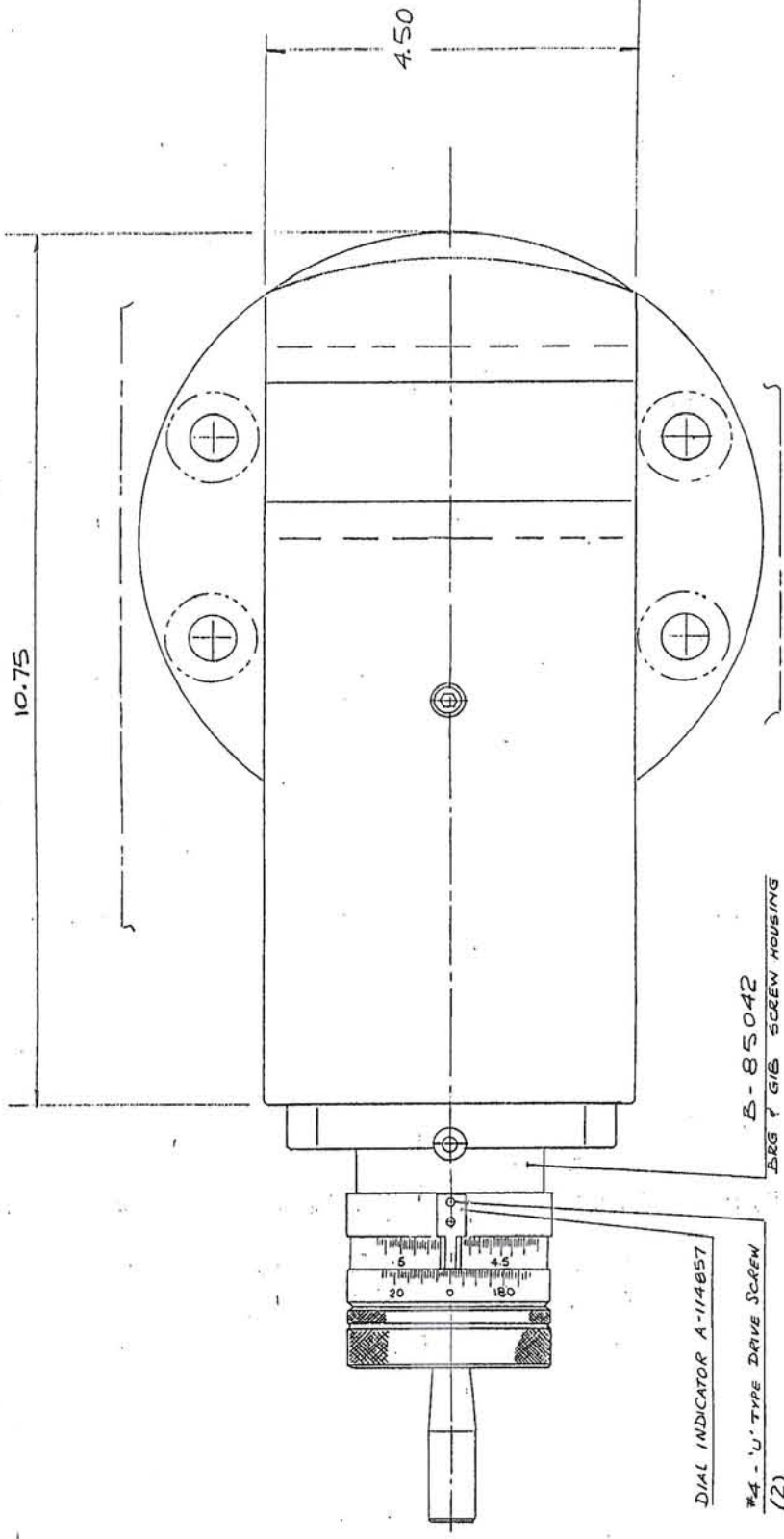
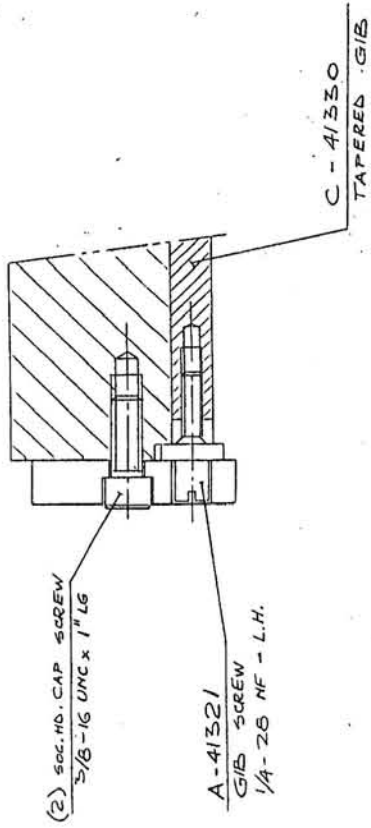

DIAL INDICATOR A-114857
 #4 - 'U' TYPE DRIVE SCREW
 (2)

(3) #6-32 x 3/8 LG
 2 PC. HD. CAP. SCREW

GITS. OILER #522

TORRINGTON THURST RACE (4)
 #TRES-B15 (.060/.063 THK)

TORRINGTON THURST BEARING (2)
 #NTA-B15 (-.071)

#406 WOODRUFF KEY
 (1/8" x 3/4" DIA.)

INCH METRIC DIAL 8-114441

A-114440 HAND WHEEL / HUB

NYLON. HEX-NUT 1/2-20 NF

A-84882 HAND

S.H.C.S. 1/4-20 UNC x 2 1/8

DIAL SCREW A-83673

SPINDLE

2.125

9.750 REF

1.375

4.125

3.500

5.0 TOTAL TRAVEL

HEX SOC PIPE PLUG 1/8 NPT
 TO BE LEVEL OR BELOW TOP SURFACE

1 3/4 BACK

1.50

2.38

.56

.56

C-41498 SWIVEL BASE

61 REF

MOUNTING PLATE
 A-114439

DOWN 5/8 DIA. x 2 1/8

STANDARD-MODERN TOOL COMPANY LIMITED		TORONTO, CANADA	
ITEM NO.	REVISED	DATE	BY
C-41498	1		
TITLE		COMPONENT SIDE ASSY	
PART NO.		INCH-METRIC DIAL	
DATE		AUG 90	
SCALE		FULL	
REF. D-85006		20 INCH LATHES	
SHEET		1 OF 1	
DRAWING NO.		D-11493B	

SECTION A-A

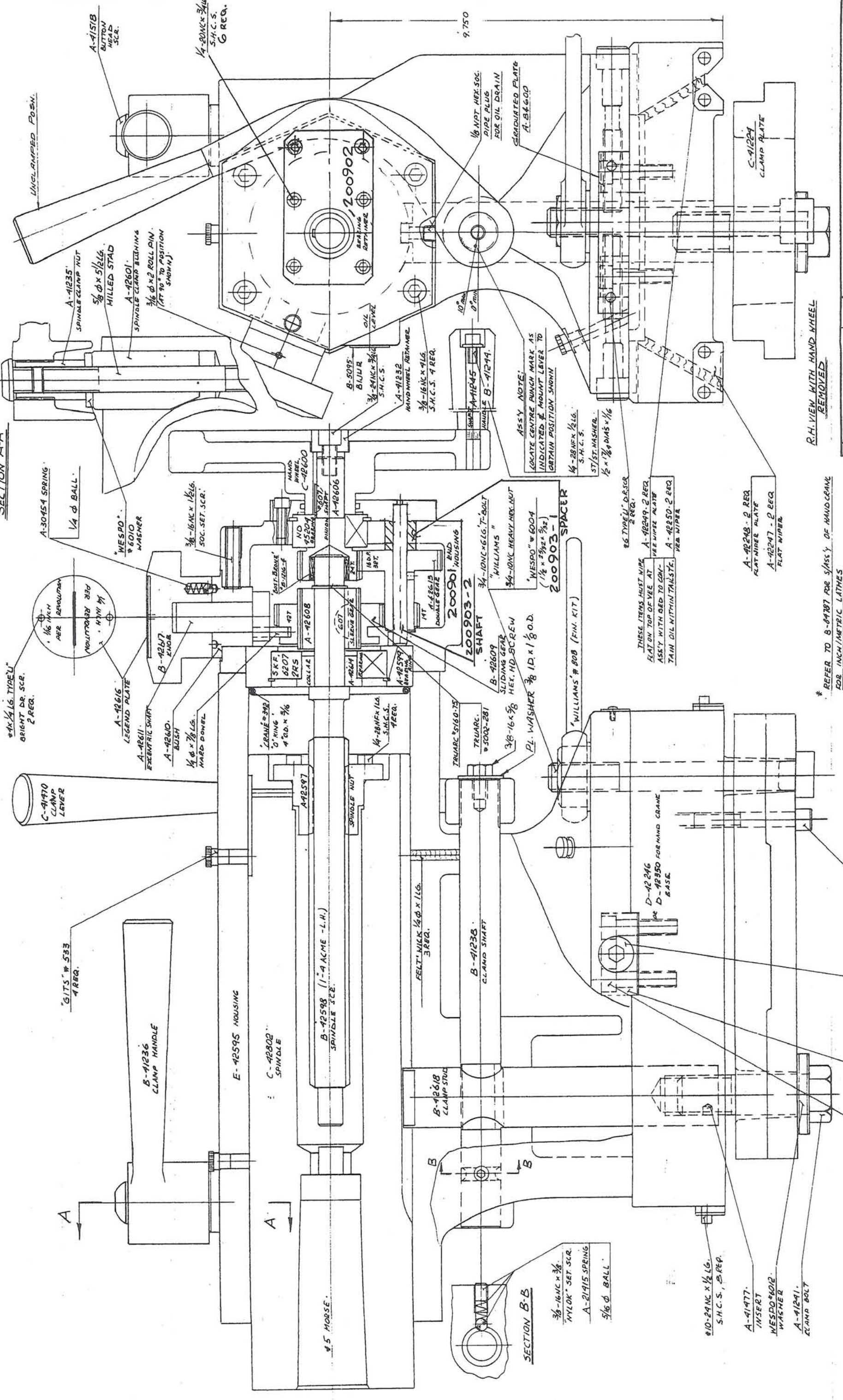

ASSY NOTE:
LOCATE CENTRE PUNCH MARK AS INDICATED & MOUNT LEVER TO OBTAIN POSITION SHOWN

1/4-28 NEX. 1/2 LG. S.H.C.S.
ST/ST. WASHER.
1/2 x 1/8 DIAS x 1/16

THESE ITEMS MUST NIP FLAT ON TOP OF VEE AT THE WIRE PLATE ASSY WITH BED TO CONTAIN OIL WITHIN TANKSTE.

A-42248 - 2 REQ. FLAT NIPER PLATE
A-42247 - 2 REQ. FLAT NIPER

* REFER TO B-84787 FOR S/ASSY OF HAND CRANK FOR INCH/METRIC LATHES

** REFER TO D-12547 FOR S/ASSY OF HAND CRANK

LOCHELL 3/8-16 X 2 1/2 ADJUST FOR ODD CLEARANCE WHEN PLATE IS CLAMPED.

A-41242 REQ. ADJUST SCR.

A-41243 REQ. ADJUST BOLT

3/8-16 NC x 1 1/2 LG. S.H.C.S. 1 REQ.

SECTION B-B
3/8-16 NC x 3/8 NYLON SET SCR.
A-21415 SPRING
5/16 Ø BALL

A-41241 CLAMP BOLT

A-41240 INSERT WASHER

Ø 10-24 NC x 1/2 LG. S.H.C.S. 5 REQ.

R.H. VIEW WITH HAND WHEEL REMOVED

STANDARD-MOORE TOOL COMPANY LIMITED	TORONTO, CANADA
DATE: 1/15	REV: 2
BY: [Signature]	CHK: [Signature]
APP: [Signature]	DES: [Signature]
200902	200900
2 SPEED TAILSTOCK ASSY	20 INCH LATHES
3/8 MOORE SPINDLE	
WITH WAYS LUBRICATION	

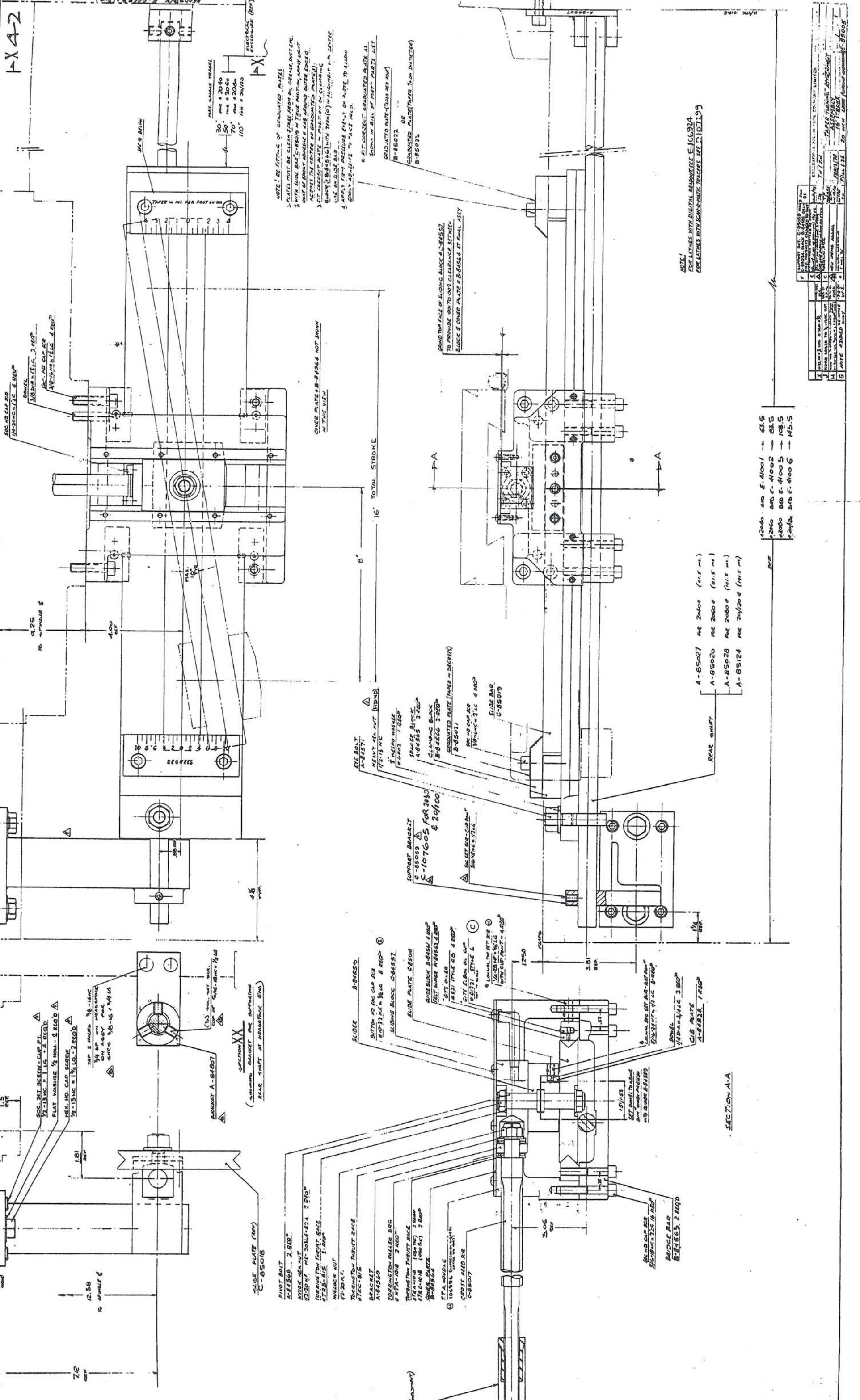

NOTE: BE SETTING OF GRADUATED PLATE
 1 PLATE MUST BE CLEAN FREE FROM OIL, GREASE, BUTTER, ETC.
 2 WITH SLIDE BAR C-85079 IN TRUE POSITION, APPLY LIGHT
 COAT OF SPINNY ADHESIVE & ASSEMBLE OUTER EDGE OF
 3 FIT CORRECT PLATE IN POSITION OF GRADUATED PLATE.
 4 BRIDGE BAR B-84555 WITH ZERO (0) IN ALIGNMENT WITH CENTER
 LINE AND SLIDE BAR.
 5 APPLY LIGHT MEASURE PAPER ON PLATE TO ALLOW
 6 ADJUST ADHESIVE TO TAKE HOLD.
 7 FIT CORRECT GRADUATED PLATE AS
 SHOWN IN BILL OF MATERIAL PARTS LIST
 GRADUATED PLATE (PART NO. NOT)
 B-85021 OR
 GRADUATED PLATE (PART NO. NOT)
 B-85023

COVER PLATE B-84554 NOT SHOWN
 IN THIS VIEW

GRIND TOP FACE OF SLIDING BLOCK B-84557
 TO PROVIDE .002 TO .003 CLEARANCE BETWEEN
 BLOCK & COVER PLATE B-84554 AT REAR ASSY

NOTE:
 FOR LATHES WITH DIGITAL READOUT SEE E-166924
 FOR LATHES WITH SCREW-NOTE TRACERS SEE D-191719

SECTION A-A

12040	REV E-41001	63.5
12060	REV F-41002	63.5
12080	REV G-41003	105.5
12100	REV H-41004	145.5

1	PIVOT BOLT	A-8515B	2 REQ
2	BRACKET	A-8515A	2 REQ
3	SLIDING BLOCK	C-84557	1 REQ
4	SLIDE PLATE	C-8508	1 REQ
5	SLIDER	B-84555	1 REQ
6	SUPPORT BRACKET	C-85059	2 REQ
7	CLAMPING BLOCK	B-84556	2 REQ
8	CLAMPING PLATE	B-84554	2 REQ
9	GRADUATED PLATE	B-85021	1 REQ
10	SLIDE BAR	C-85079	1 REQ
11	REAR SHIFTER	A-85027	1 REQ
12	BRIDGE BAR	B-84555	2 REQ

REVISIONS

NO.	DATE	DESCRIPTION
1	10/1/58	INITIAL DESIGN
2	11/1/58	REVISED FOR MANUFACTURE
3	12/1/58	REVISED FOR MANUFACTURE
4	1/1/59	REVISED FOR MANUFACTURE
5	2/1/59	REVISED FOR MANUFACTURE
6	3/1/59	REVISED FOR MANUFACTURE
7	4/1/59	REVISED FOR MANUFACTURE
8	5/1/59	REVISED FOR MANUFACTURE
9	6/1/59	REVISED FOR MANUFACTURE
10	7/1/59	REVISED FOR MANUFACTURE
11	8/1/59	REVISED FOR MANUFACTURE
12	9/1/59	REVISED FOR MANUFACTURE
13	10/1/59	REVISED FOR MANUFACTURE
14	11/1/59	REVISED FOR MANUFACTURE
15	12/1/59	REVISED FOR MANUFACTURE

APPROVED: [Signature]
 DATE: 10/1/58