

OPERATORS HANDBOOK

INDEX

	PAGE NUMBER
General View	1
Lifting and Installation Instructions	2,3
Electrical Diagram	4
Lubrication	5,6
Operating Instructions	7-13
Maintenance Instructions	14-19

ASSEMBLY DRAWINGS AND PARTS LISTS

General Assembly	20,21
Headstock Assembly	22
Feedbox Assembly	23,24
Apron Assembly	25
Compound Slide Assembly	26
Cross Slide and Saddle Assembly	27
Tailstock Assembly	28
Telescopic Taper Turning Attachment (Sheet 1)	29
Telescopic Taper Turning Attachment (Sheet 2)	30
Depth Threading Stop Assembly	31
Micrometer Carriage Stop Assembly	32
Drawbar Collet Attachment Assembly.	33
Steady Rest Assembly	34

MODEL 1340 I/M LATHE

D1-4" SPINDLE NOSE

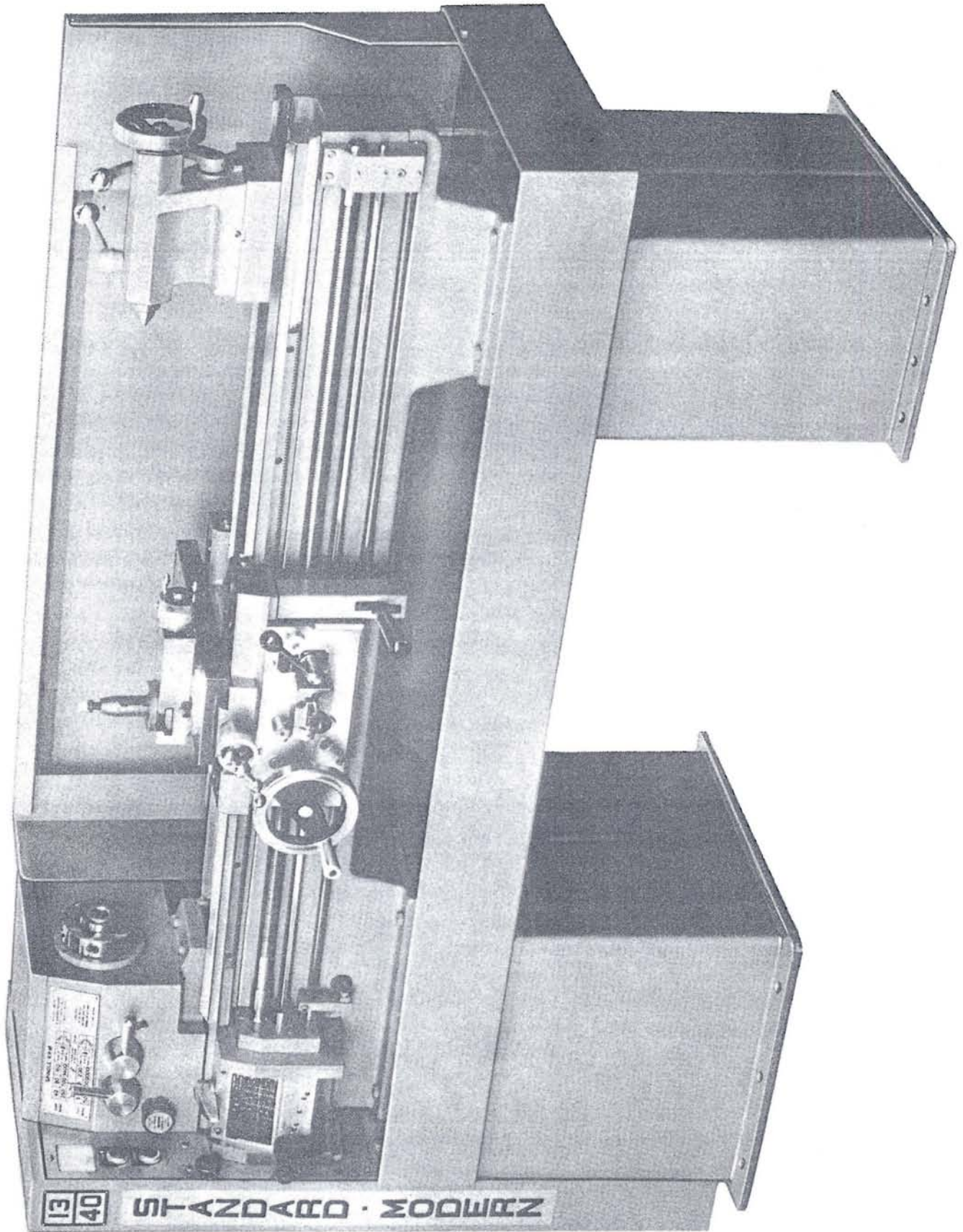

GENERAL VIEW

1. LIFTING AND INSTALLATION INSTRUCTIONS.

1.1 Lifting the machine.

To lift the machine by the use of chain slings, run the carriage down to the tailstock and place the slings around the centre bed cross rib. (See Fig. 1.) Protect painted surfaces with thick pads.

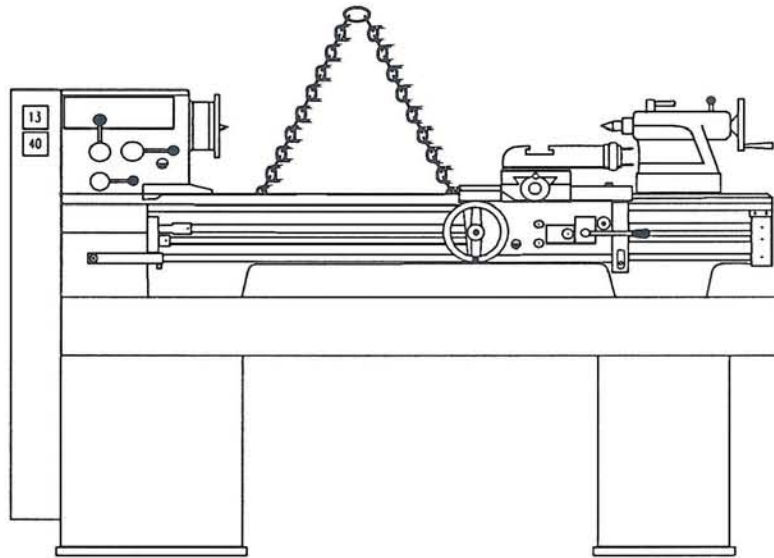

Figure 1.

Do not attempt to lift this machine with a hoist having less than one ton capacity. The shipping weight of the machine including electrics is 1750 lbs.

Do not remove skids from the machine until it is brought to its final position especially if the machine is to be moved on rollers.

1.2 Cleaning

All unpainted parts of the machine have been coated with an anti-rust compound. This should be thoroughly removed after the machine is installed and before moving the carriage, compound rest or tailstock on their respective slides.

To remove the anti-rust compound, use a wiper dipped in Varsol or kerosene.

All unpainted surfaces should immediately be coated with a film of light machine oil to prevent rust. If the finished surfaces are kept clean and well coated with oil, the lathe will retain its new appearance indefinitely.

1.3 Inspection

Check your delivery slip against the accessories that were ordered with the machine. If there is a shortage or error, report it to **STANDARD-MODERN LATHES INC.** immediately, giving the Serial number of the machine which is stamped into the recessed face on top of the bed at the tailstock end.

1.4 Installation

For proper operation, the machine should be set on a substantial floor capable of supporting the weight safely. To secure the machine on its foundation, use anchor bolts or lag screws. For the size of the lathe and the location of the bolt holes see Figure 2.

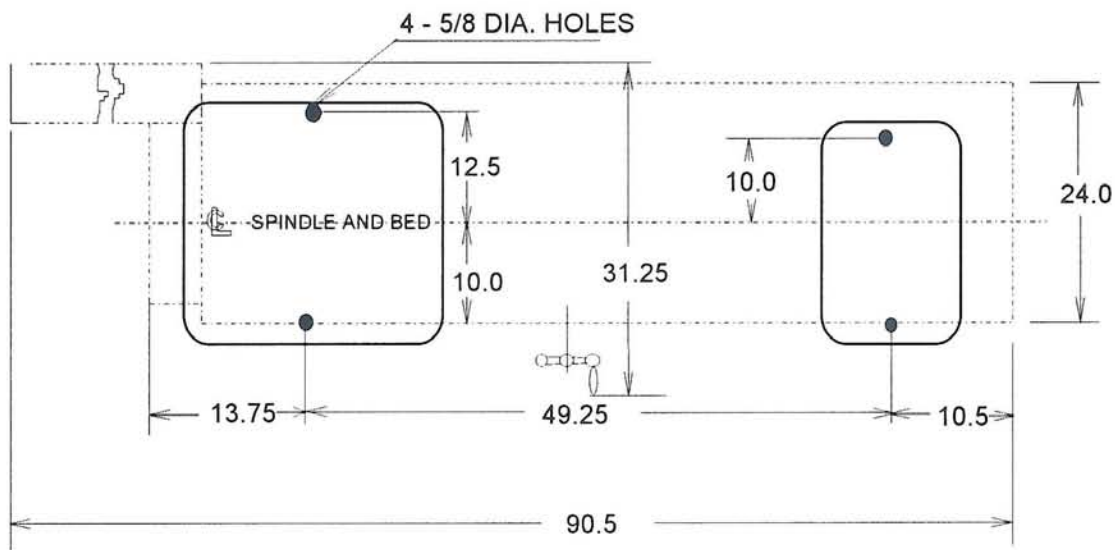

Figure 2.

After the machine is in position, it must be levelled by use of the four levelling bushings before tightening lag screws. It is important that the lathe be level in order to produce accurate work.

Use a precision level placed lengthwise and crosswise on the bed. To take a reading off the level for the crosswise levelling of the bed, use parallel bars placed on the flats of the bed.

After all the strain and twist has been removed from the lathe bed and it checks perfectly level, the legs should be lagged to the floor and the leveling rechecked. Recheck the level of the machine at regular intervals.

CUSTOMER SUPPLY

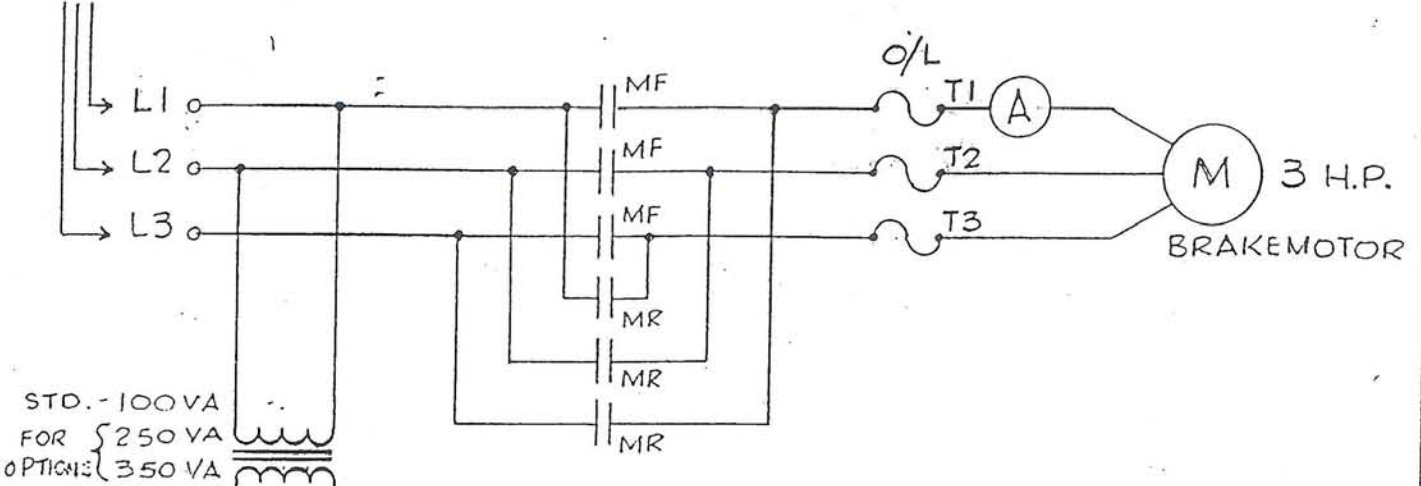

STD. - 100VA
FOR 250VA
OPTION: 350VA

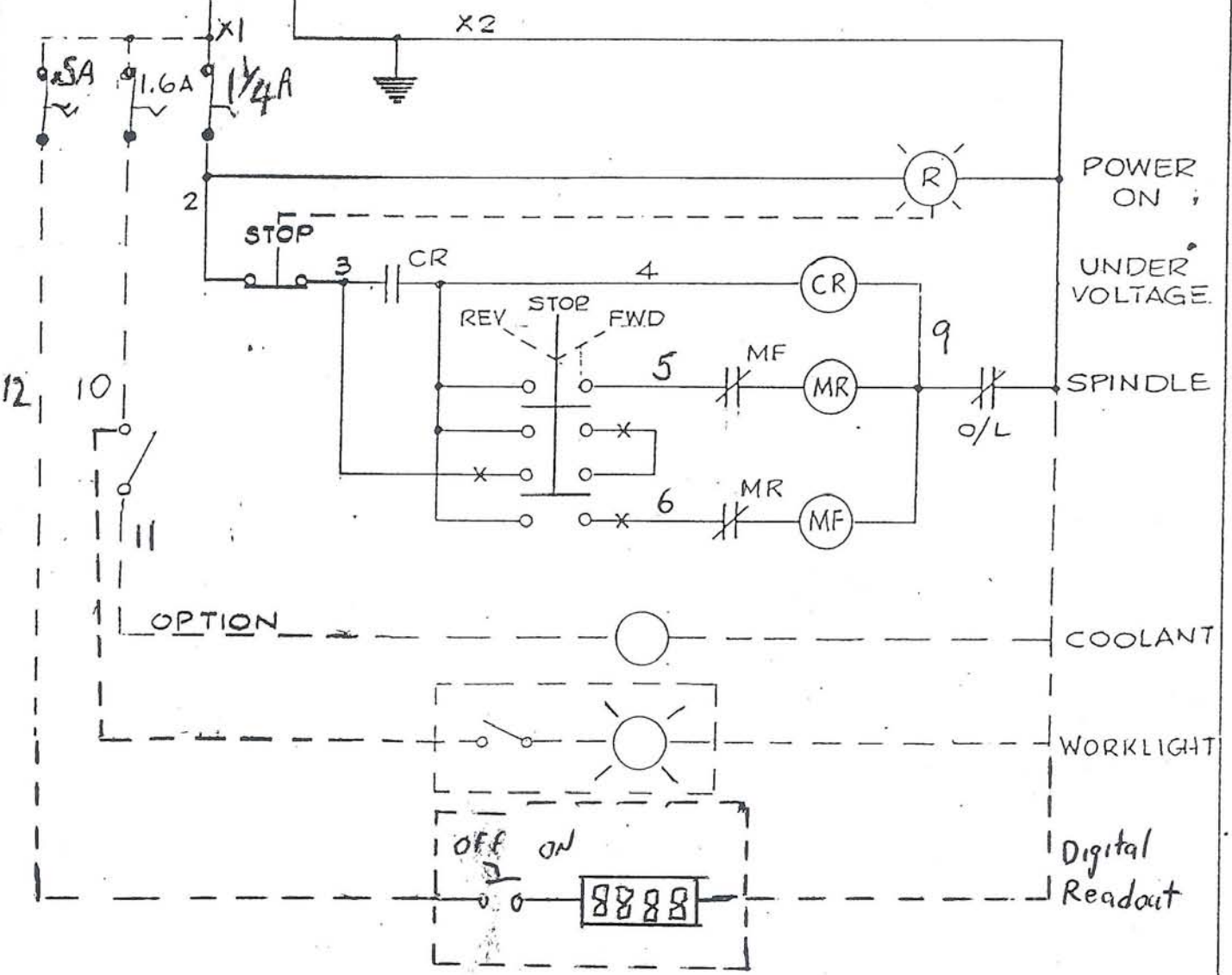

ORIGINAL MACHINE TOOLS INC.			
B	CIRCUIT REPAIRED REPLACED FUSE OPTIONS UPDATED	G.L. FR897	BY G.L.
A	CR REROUTED TO 10 FROM X2	G.L. APR 94	DATE JUL 91
		ELEMENTARY DIAGRAM	
		1340 (COMMERCIAL)	
		SHT. 1 OF 1	
		NO. A115252	

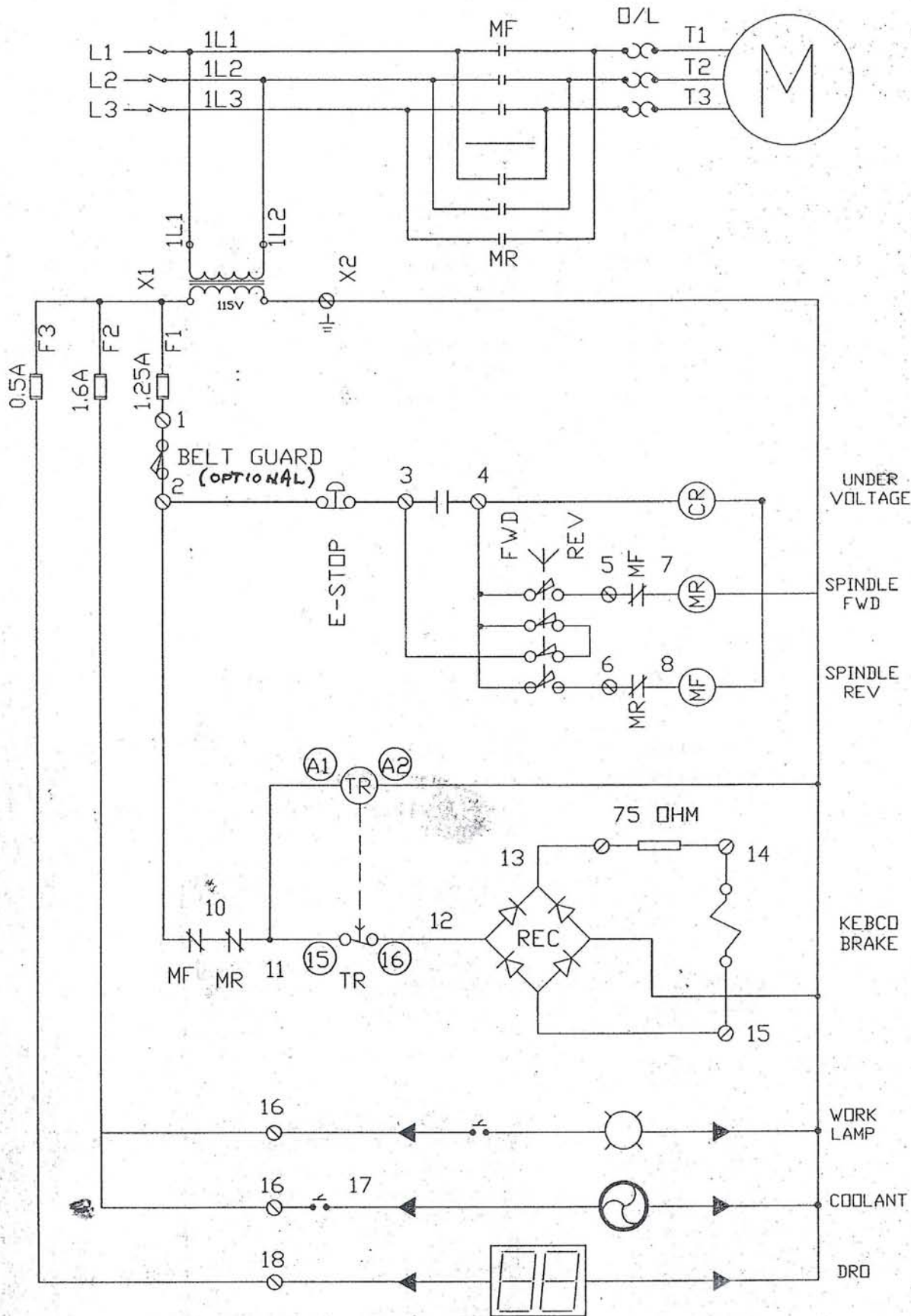

STANDARD MODERN LATHES	
DRN RB	13 INCH LATHE 3 HP MOTOR AND KEBCO BRAKE
DATE JUL 2010	DWG NO. 117723-2

ELECTRICAL PARTS LIST
(DIAGRAM A-115252) MODEL 1334 LATHE.

PART NUMBER	MANUFACTURER	CODE	QTY	NOMENCLATURE
117046	A.B.B.	B16C-1	2	CONTACTOR, 3 POLE
117108	TELEMECANIQUE	ZCKJ0404-H7	1	LIMIT SWITCH
117110	TELEMECANIQUE	ZB2BW64	1	PUSH BUTTON
117277	T&B	EFC-050	10 ft	CONDUIT, 1/2 FLEX.
117346*	SHURITE	8508-Z 0-15AMP	1	AMMETER
117404	A.B.B.	S271-K1A	1	CIRCUIT BREAKER
117499	IDEC	RH1B-U-AC120	1	RELAY, UVR
117573	A.B.B.	CA7-01	2	CONTACT, AUX
117584	S&S	19.114.004.01	12	BLOCK, TERM.
117585	S&S	19.115.004.01	1	BARRIER, END
117586	WIELAND	25.522.7453	2	CLAMP, END
117605*	A.B.B.	T25DU(230/460V)	1	RELAY, THERMAL O/L
117606	A.B.B.	AB25/25A	1	STAND, OVERLOAD
117625**	A.B.B.	T25DU (575V)	1	RELAY, THERMAL O/L
117629	A.B.B.	VB-30	1	INTERLOCK
117634	IDEC	SH1B-05	1	BASE, RELAY
117637*	MARCUS	MO350E	1	TRANSFORMER, OPEN (P230-460/S120)350VA
117644**	MARCUS		1	TRANSFORMER, OPEN (P575/S120) 350VA
117649	HAMMOND	1414 PHK	1	ENCLOSURE
117650	TELEMECANIQUE	ZB2BW062	1	CONTACT; N.C.
117651	TELEMECANIQUE	ZCKY11	1	ACTUATOR, SWITCH
117653	T&B	5332	4	CONNECTOR, CONDUIT 1/2"
117657**	SHURITE	8504-ZDP 0-10A	1	AMMETER
117659**	BROOK-HANSEN		1	MOTOR, 3HP, 575/3/60 (BRAKE)
118322*	BROOK-HANSEN		1	MOTOR, 3HP, 230-460/3/60 (TEFC, BRAKE)
118483	A.B.B.		1	NAMEPLATE, PUSH-STOP PULL-START
85708	CSA		1	NAMEPLATE

Note: Option I - Items marked *; Option II - Items marked **

2. LUBRICATION

All machines are shipped with the lubricating oil drained from the oil sumps in the headstock, feedbox and apron and must be serviced before being put into use.

For proper lubrication, follow the instructions listed in this manual.

2.1 Headstock

An automatic splash type of lubrication provides an even distribution of oil to all gears and bearings in the headstock.

To service the headstock, fill the reservoir to the centre of the oil sight gauge through the oil filler accessed by opening the belt guard.

A high grade S.A.E. No 30 oil should be used.

The reservoir capacity of the headstock is 1 Imperial or 1.2 U.S. gallons.

Depending on operating conditions, usually about every six months, the headstock should be drained and thoroughly flushed out, before adding new oil.

A light blending oil to which a small percentage of kerosene has been added may be used to flush out any dirt or sediment.

Run the machine for several minutes without load so that the flushing oil can circulate through the reservoir and remove the dirt. The flushing oil must then be drained and new oil added.

DO NOT FLUSH WITH SOLVENTS which will soften and remove the paint.

2.2 Totally Enclosed Quick-change Feedbox

An automatic splash type of lubrication provides an even distribution of oil to all gears and bearings in the Quick-change Gear Box. The reservoir capacity is 1½ quarts. Use an S.A.E. No 30 oil. The oil filler is accessed by opening the belt guard and is located below the headstock filler.

2.3 Carriage

Two oilers located on the right hand side of the carriage lubricate the bearing surfaces of the carriage on the bed ways.

The oil flows down through the oilers to the ways, then along the length of the carriage through oil grooves. The oil is retained at the bearing surfaces by felt seals located at either end of the carriage, which also provide even distribution of the lubricant over the ways.

2.4 Apron

The box construction of the apron completely encloses all moving parts and prevents the entry of dust or dirt.

The lower half of the apron forms a large oil reservoir in which all the gears run to provide an even distribution of lubricant.

Service the apron reservoir through the ¼" pipe plug in the saddle casting.

Fill with oil to the centre of the oil sight gauge using a S.A.E. No. 30 oil. The reservoir capacity of the apron is ½ pint Imperial or U.S. measure.

The apron oil reservoir should be drained, flushed with kerosene and refilled with fresh clean oil at least once every 6 months.

Two grease points service the half nut and the feed dial.

LUBRICATION (CONTINUED)

2.5 Tailstock

The spindle and screw are lubricated by an oiler located on top of the spindle housing.

The bed ways on which the tailstock slides should be cleaned and oiled frequently.

Dry red lead mixed with machine oil to a creamy consistency is an excellent lubricant for the tailstock centre when machining work between centres.

2.6 Compound Slide and Cross Slide.

On the compound slide, one flush-type oiler lubricates both ways and screw, while another lubricates the screw bearing.

On the cross feed, the screw bearing is lubricated by an oiler behind the cross-feed dial. An oiler behind the compound swivel base lubricates the cross-feed nut.

Two oilers on the cross slide lubricate the saddle ways individually.

2.7 Bed End Bracket

Three grease points located on the front face of the bed end bracket, lubricate the ends of the leadscrew, feed shaft and control shaft.

2.8 Taper Attachment

One oiler on the cross guide bar lubricates the cross feed screw thrust bearing and should be filled with oil at least once each week. Before using the taper attachment, apply a few drops of oil to the two oilers on the slide casting and all moving parts.

2.9 Miscellaneous Lubrication

For all oilers on the machine, use a medium S.A.E. No. 30 machine oil. Before filling reservoirs or oil cups, always wipe off with a clean rag, any accumulation of old oil, grease or dirt that might get into a part being lubricated.

2.10 Caution.

Do not mix detergent type automotive oil or multi-purpose oils with the regular grade of S.A.E. No. 30 lubricating oil.

3. OPERATING INSTRUCTIONS

3.1 Motor Drive

The electric motor is located on the inside back face of the headstock pedestal. Power drive to the headstock input shaft is by means of a 2-speed drive arrangement with Super HC vee belts.

Both belts are the same length and are interchangeable with each other.

When replacing belts, loosen the motor plate mounting screws at the back of the headstock pedestal and lift the motor plate. Both belts can readily be removed and replaced. With new belts in position, lower the motor plate until the belts are properly tensioned and retighten mounting screws. For the correct belt tension, use the following simple method:-

At the centre of the span, apply a force of 5 lbs using a spring scale at right angles to the span to deflect the belt .5 inch.

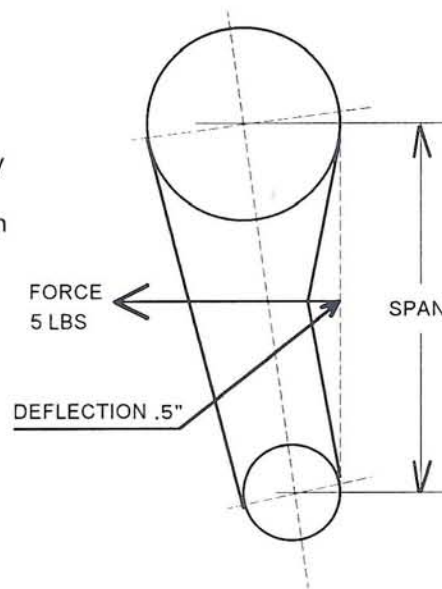

Check the tension frequently during the first day of operation and periodically thereafter. Keep the pulleys and belts clean and free from any foreign material to ensure long life and better traction. The belt drive is accessible from the hinged belt guard at the LH end of the headstock.

3.2 Motor and Spindle Rotation Control

The electrical circuit for the motor is energized by pulling the 'STOP' button, located at the left end of the headstock, thereby supplying power to a 3-position control switch.

Spindle rotation is controlled by a control lever located at the RH end of the apron. The control lever operates a control shaft which, in turn, actuates the 3-position control switch.

Shifting the lever up gives forward rotation of the spindle for normal turning and drilling operations.

Pushing the lever down gives reverse spindle rotation. A short side shift is required when shifting from "Forward" to "Reverse" or vice-versa. This side shift occurs at the central position and with the lever in this position, the motor and spindle will stop.

Pushing the 'STOP' button de-energizes the electrical circuit. If the 'STOP' button is pushed while the control lever is up or down, the motor and spindle will stop and cannot be restarted until the control lever is returned to neutral.

OPERATING INSTRUCTIONS (CONTINUED)3.3 Spindle Speed Selection

The SPINDLE SPEED CHART is located on the upper front face of the headstock.

SLOW RANGE:	40	80	160	350	700	1400
FAST RANGE:	57	115	230	500	1000	2000

The desired spindle speed range is obtained by moving the KNURLED KNOB located in a recess near the top of the belt guard.

To select SLOW range, push and twist.

To select HIGH range, pull and twist.

Any spindle speed within that range can be obtained by moving the 3-POSITION SHIFTER KNOB and the HIGH-LOW shifter. For free hand rotation of the spindle, move the HIGH-LOW shifter to its mid-position.

- WARNING** - STOP the motor before operating any speed selectors.
- DO NOT exceed the spindle speed recommended by the chuck manufacturer.
 - DO NOT operate the machine with the large faceplate above 500 rpm.

3.4 POWER FEEDS

The trip clutch pre-load is factory set and should not require adjustment.

A safety interlock is fitted so that it is impossible to engage the POWER FEED ENGAGEMENT LEVER and the HALF-NUTS LEVER at the same time.

To select power longitudinal feed or power cross feed, select COARSE or FINE range by means of the PUSH-PULL PLUNGER which protrudes through the belt guard and arrange the A-B-C handle, INCH-METRIC shifter knob and TUMBLER ARM to obtain the desired feed rate according to the feeds and threads chart.

WARNING: STOP the motor before moving the PUSH-PULL PLUNGER.

CAUTION: DO NOT USE THE COARSE RANGE OF FEEDS WHEN SPINDLE SPEEDS ARE ABOVE 140 RPM.

(REFER TO PAGE 9 FOR LIST OF FEEDS)

The POWER FEED ENGAGEMENT LEVER is located centrally on the apron. Move up for longitudinal feed and down for cross feed. A short side shift is required before shifting from long feed to cross feed and vice versa to prevent accidental through shifting.

NOTE: The power cross feed rate is half the longitudinal rate.

FEED RATES

INCH (Inches per revolution)				METRIC (Millimeters per revolution)			
FINE		COARSE		FINE		COARSE	
.001	C9	.009	C9	.031	A1	.249	A1
.0011	C8	.0092	C8	.035	A2	.28	A2
.0012	C7	.0096	C7	.039	A3	.312	A3
.0013	C4	.0104	C4	.042	A5	.344	A5
.0013	C6	.0108	C6	.044	A6	.358	A6
.0014	C5	.011	C5	.046	A4	.374	A4
.0016	C3	.0124	C3	.05	A7	.405	A7
.0017	C2	.0138	C2	.052	A8	.42	A8
.0019	C1	.0156	C1	.054	A9	.44	A9
.0021	B9	.0178	B9	.062	B1	.5	B1
.0023	B8	.018	B8	.07	B2	.56	B2
.0024	B7	.019	B7	.078	B3	.62	B3
.0026	B4	.021	B4	.085	B5	.69	B5
.0027	B6	.022	B6	.089	B6	.72	B6
.0028	B5	.023	B5	.093	B4	.75	B4
.0031	B3	.025	B3	.101	B7	.81	B7
.0035	B2	.028	B2	.105	B8	.84	B8
.0039	B1	.031	B1	.109	B9	.87	B9
.0044	A9	.036	A9	.124	C1	1.0	C1
.0046	A8	.037	A8	.14	C2	1.12	C2
.0048	A7	.038	A7	.156	C3	1.25	C3
.0052	A4	.042	A4	.171	C5	1.37	C5
.0054	A6	.043	A6	.179	C6	1.43	C6
.0057	A5	.045	A5	.187	C4	1.5	C4
.0062	A3	.05	A3	.202	C7	1.62	C7
.007	A2	.055	A2	.21	C8	1.68	C8
.008	A1	.062	A1	.218	C9	1.74	C9

THREADS

THREADS PER INCH				MM PITCH			
FINE		COARSE		FINE		COARSE	
224	C9	28	C9	.125	A1	1.000	A1
216	C8	27	C8	.141	A2	1.125	A2
208	C7	26	C7	.156	A3	1.250	A3
192	C4	24	C4	.172	A5	1.375	A5
184	C6	23	C6	.180	A6	1.438	A6
172	C5	22	C5	.188	A4	1.500	A4
160	C3	20	C3	.203	A7	1.625	A7
144	C2	18	C2	.211	A8	1.688	A8
128	C1	16	C1	.220	A9	1.750	A9
112	B9	14	B9	.250	B1	2.000	B1
108	B8	13-1/2	B8	.281	B2	2.250	B2
104	B7	13	B7	.313	B3	2.500	B3
96	B4	12	B4	.344	B5	2.750	B5
92	B6	11-1/2	B6	.359	B6	2.875	B6
88	B5	11	B5	.375	B4	3.000	B4
80	B3	10	B3	.406	B7	3.250	B7
72	B2	9	B2	.422	B8	3.375	B8
64	B1	8	B1	.430	B9	3.500	B9
56	A9	7	A9	.500	C1	4.000	C1
54	A8	6-3/4	A8	.563	C2	4.500	C2
52	A7	6-1/2	A7	.625	C3	5.000	C3
48	A4	6	A4	.688	C5	5.500	C5
46	A6	5-3/4	A6	.719	C6	5.750	C6
44	A5	5-1/2	A5	.750	C4	6.000	C4
40	A3	5	A3	.813	C7	6.500	C7
36	A2	4-1/2	A2	.844	C8	6.750	C8
32	A1	4	A1	.875	C9	7.000	C9

OPERATING INSTRUCTIONS (CONTINUED)

3.5 Thread Cutting.

When cutting screw threads, set shifters as described in paragraph 3.4 to correspond with the required T.P.I. indicated on T.P.I. and feed chart.

To engage apron for threading, the half-nuts are brought into mesh with the leadscrew by pushing down the half-nut lever, located at the R.H. end of the apron. To disengage, lift up half-nut lever.

3.6 Thread Chasing Dial

The thread chasing dial is conveniently located adjacent to the half-nut lever and is marked with 4 numbered divisions and four un-numbered half divisions. A four inch traverse of the carriage gives one complete turn of the dial.

To engage half-nuts at the correct position when thread cutting, use the following rules:-

- (i) When the number of T.P.I. is divisible by 6, disregard the dial.
- (ii) When the number of T.P.I. is even (i.e. 10, 14, TPI) engage the half-nuts at any graduation.
- (iii) When the number of T.P.I. is odd (i.e. 9, 15, TPI) engage the half-nuts at numbered graduations only.
- (iv) For half T.P.I (i.e. $3\frac{1}{2}$, $4\frac{1}{2}$, TPI) engage the half-nuts on opposite numbered graduations only e.g. 1 and 3; or 2 and 4.
- (v) For quarter T.P.I. (i.e. $3\frac{3}{4}$, $5\frac{3}{4}$, TPI) engage the half-nuts at the same numbered graduation each time.

When cutting metric, module or diametral pitches, the thread chasing dial cannot be used. In these cases it is necessary to keep the half-nuts engaged during the entire thread cutting operation and to use the spindle reverse to return the carriage to its starting location after each cut.

3.7 Camlock Stud Adjustment.

Camlock studs, required for all faceplates, chuck adaptors etc., must be properly adjusted in order to be held securely by the cams in the spindle nose.

- (i) Turn studs in until reference line is flush with finished face of plate or adaptor.
- (ii) Continue turning stud in until groove lines up with lock screw hole. (Ref. line must be flush or below)
- (iii) Insert lock screw and tighten.

OPERATING INSTRUCTIONS (CONTINUED)3.8 Leadscrew Shear Pin

This brass shear pin (PN/ 83628) is provided to prevent damage to the leadscrew should the carriage be allowed to come in contact with the headstock or some other obstruction which acts as a positive stop. When the stoppage takes place, the leadscrew continues to turn in the half nuts and will begin to move endwise thus shearing the pin.

The shear pin can be readily replaced by first withdrawing the leadscrew from the coupling to remove the three pieces of broken pin. It is then returned to the coupling and rotated by hand until the zero line on the Leadscrew coincides with that on the coupling. A new shear pin (4 spare pins are provided with the machine) is then driven into place.

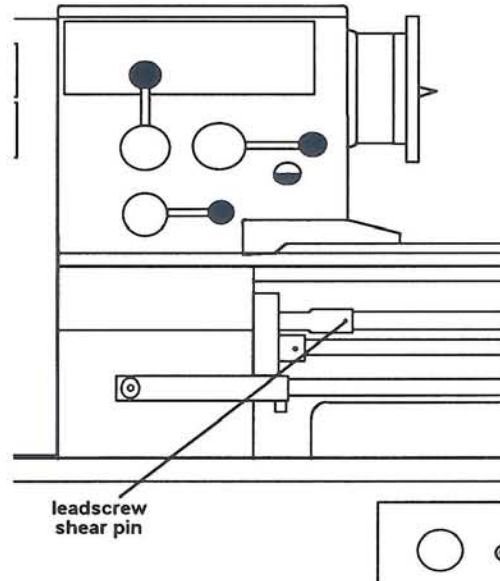
3.9 End Gear Train Shear Pin

This brass shear pin (PN/ 30398) drives the top gear of the end gear train (see below). It is provided to prevent damage to the feed gears if abnormally excessive loads are encountered.

Spare shear pins provided with the machine, are readily fitted. First remove the snap ring and 36T gear, then remove the broken portions of the pin. Assemble the 36T gear, pin and snap ring. It is important, of course, to locate and remedy the cause of the excessive load.

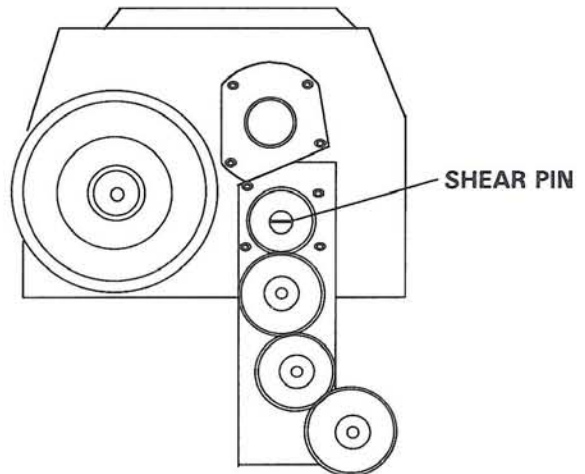

OPERATING INSTRUCTIONS (CONTINUED)3.10 Telescopic Taper Turning AttachmentFor Taper Turning:

- (i) Slacken hex clamp screw 'A'
- (ii) Locate saddle and slide casting 'B' in position required relative to workpiece and tighten 2 bed clamp nuts 'C'.
- (iii) Slacken 2 socket head cap screws 'D', set pivoted slide bar 'E' to desired taper and tighten screws 'D'
- (iv) Locate cross slide to suit diameter of workpiece.

For Straight Turning

- (i) Slacken 2 bed clamp nuts 'C'
- (ii) Tighten Hex Clamp Screw 'A'
- (iii) Leave pivoted slide bar 'E' locked in it's angular setting so that the taper attachment will move with the saddle.

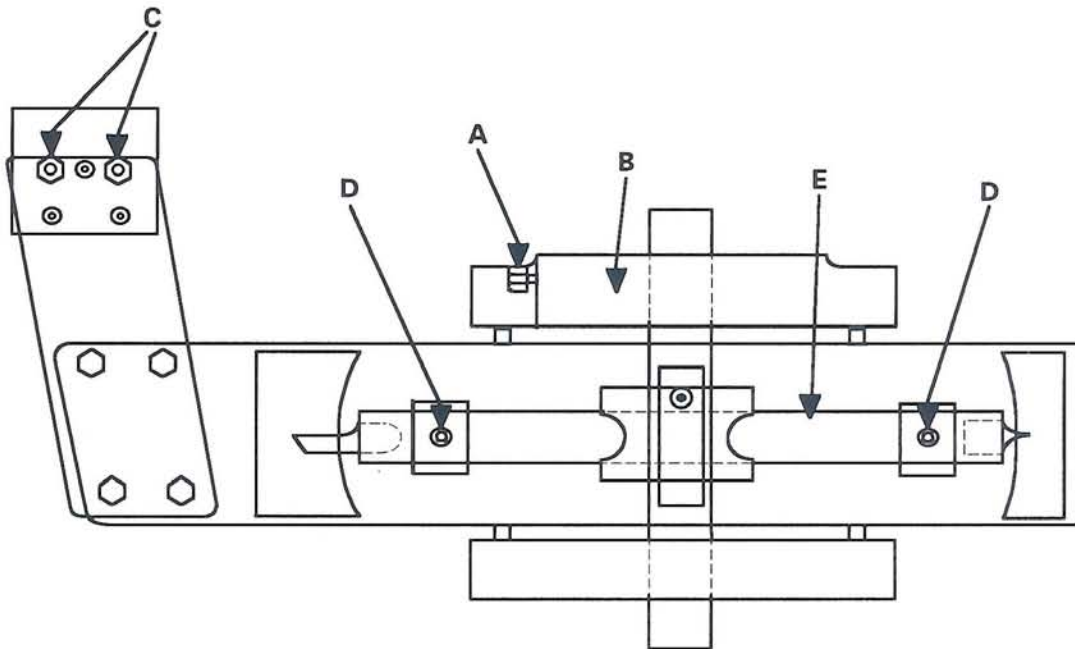
3.11 Faceplate attachment

The faceplate as shipped from the factory is rough turned on the part mounting surface and should be machined using a skim cut prior to first usage.

NOTE: Maximum safe operating speed for large face plates is 480 RPM.

4. MAINTENANCE INSTRUCTIONS4.1 Trouble Shooting Chart

TROUBLE	PROBABLE CAUSE	CORRECTION
Vibration	Loose leveling screws	Set all screws so that they bear evenly on leveling plates.
	Torn or mismatched V-belts.	Replace V-belts with matched set.
	Work or chuck out of balance operating at high spindle speeds.	Balance chuck or reduce spindle speed.
	Motor out of balance.	Contact local representative of motor manufacturer.
Chatter	Tool bit improperly ground or not on center	Reground tool bit or adjust tool holder so that area of contact between tool bit and work is decreased. Avoid extreme negative rake.
	Tool overhang too great	Keep point of tool bit as close as possible to tool holder.
	Using improper cutting speed.	Reduce or increase spindle speed.
	Feed rate too high or too low.	Reduce or increase feed.
	Gibs of cross slide or compound rest loose.	Adjust gibs.
	Spindle bearings worn or loose.	Adjust spindle bearings. (See page 17)
	Work improperly supported	Adjust tailstock center. Use steady rest or follow rest for long slender shafts. Minimize tailstock barrel extension.
	Vibration	See "Vibration" trouble above.

MAINTENANCE INSTRUCTIONS (CONTINUED)4.1 Trouble Shooting Chart (Continued)

TROUBLE	PROBABLE CAUSE	CORRECTION
Work not turned straight	Headstock and tailstock not aligned.	Align tailstock center.
	Work improperly supported.	Use steady rest or follow rest. Reduce overhang from chuck.
	Bed not level.	Re-level bed using precision level.
Work out of round.	Work loose between centers.	Adjust tailstock center.
	Centers excessively worn. Work centers out of round.	Regrind centers. Lap work centers.
	Loose headstock spindle bearings.	Adjust headstock spindle bearings. (see page 17)
Cross slide or compound rest movement does not coincide with dial.	Gib setting too tight or too loose.	Adjust gibs.
	Work is too long and slender.	Use steady rest or follow rest for long slender shafts.

PARTS ORDERING PROCEDURE

(1) Always quote the machine serial number which will be found stamped in the recessed face on top of the bed at the tailstock end.

(2) Refer to the appropriate assembly and individual part numbers taken directly from the illustrations.

NOTE: Quantity required (when other than one) is given following the Part Number itself.

HEADSTOCK BEARING PRELOAD ADJUSTMENT

The correct preload is determined by the actual force required to turn the spindle in its bearings when the spindle is in its neutral position, i.e. with the HIGH-LOW shifter and LEADSCREW REVERSE in their respective neutral positions.

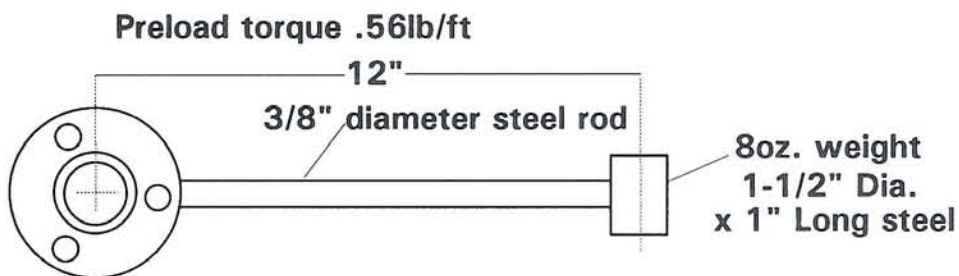

If an adjustment is required:

1. Turn the disconnect switch off.
2. Remove the headstock cover.
3. Back off two (2) 1/4-28 socket set screws in adjusting nut.
4. Turn adjusting nut clockwise to increase preload or vice-versa to decrease preload.
5. Re-tighten the set screws securely.
6. Replace the headstock cover.

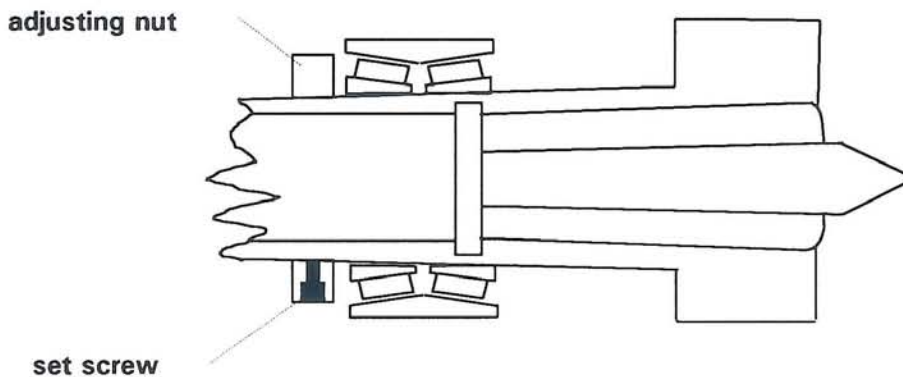

MAINTENANCE INSTRUCTIONS (CONTINUED)

4.2 Cross Slide Screw

Provision is made for the elimination of backlash in the Cross Slide Screw thrust bearing. Just tighten the 5/8-18 self locking nut shown below.

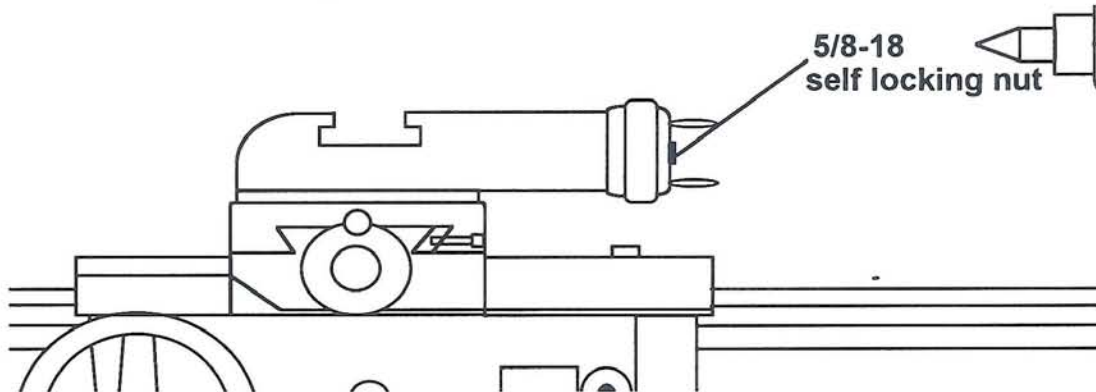

4.3 Compound Slide Ways

Wear in the Compound Slide Ways may be adjusted by means of the Tapered Gib as follows:-

Turn the slotted head Gib Screw at the handle end in a clockwise direction to tighten.

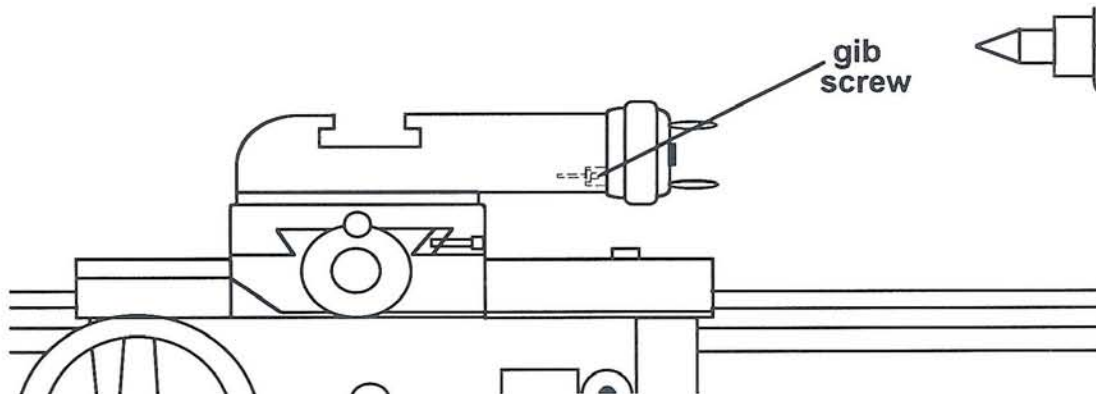

4.4 Cross slide ways

Wear in the Cross Slide Ways may be adjusted as follows:

Turn 1/4-28 socket set screws located on the right hand side of the Cross Slide in a clockwise direction to tighten the Gib.

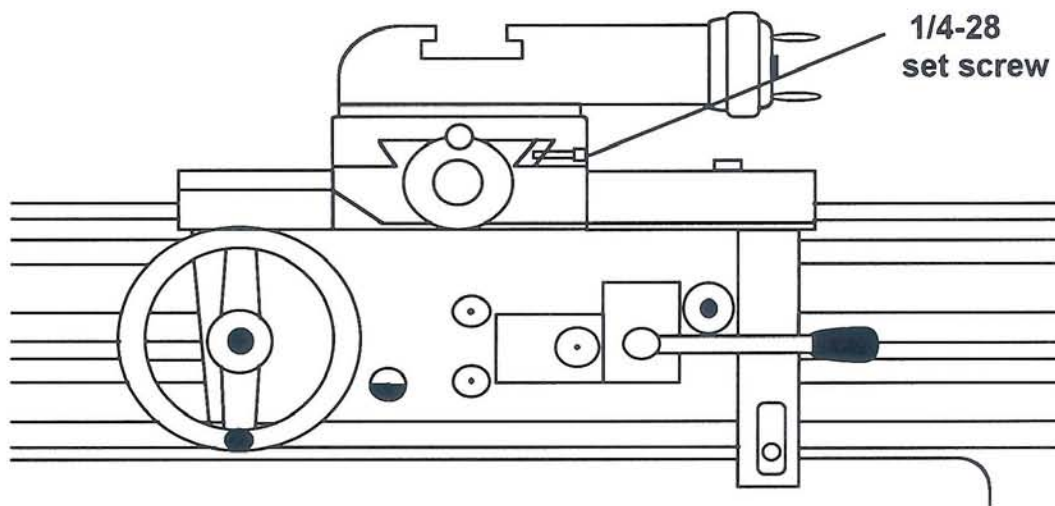

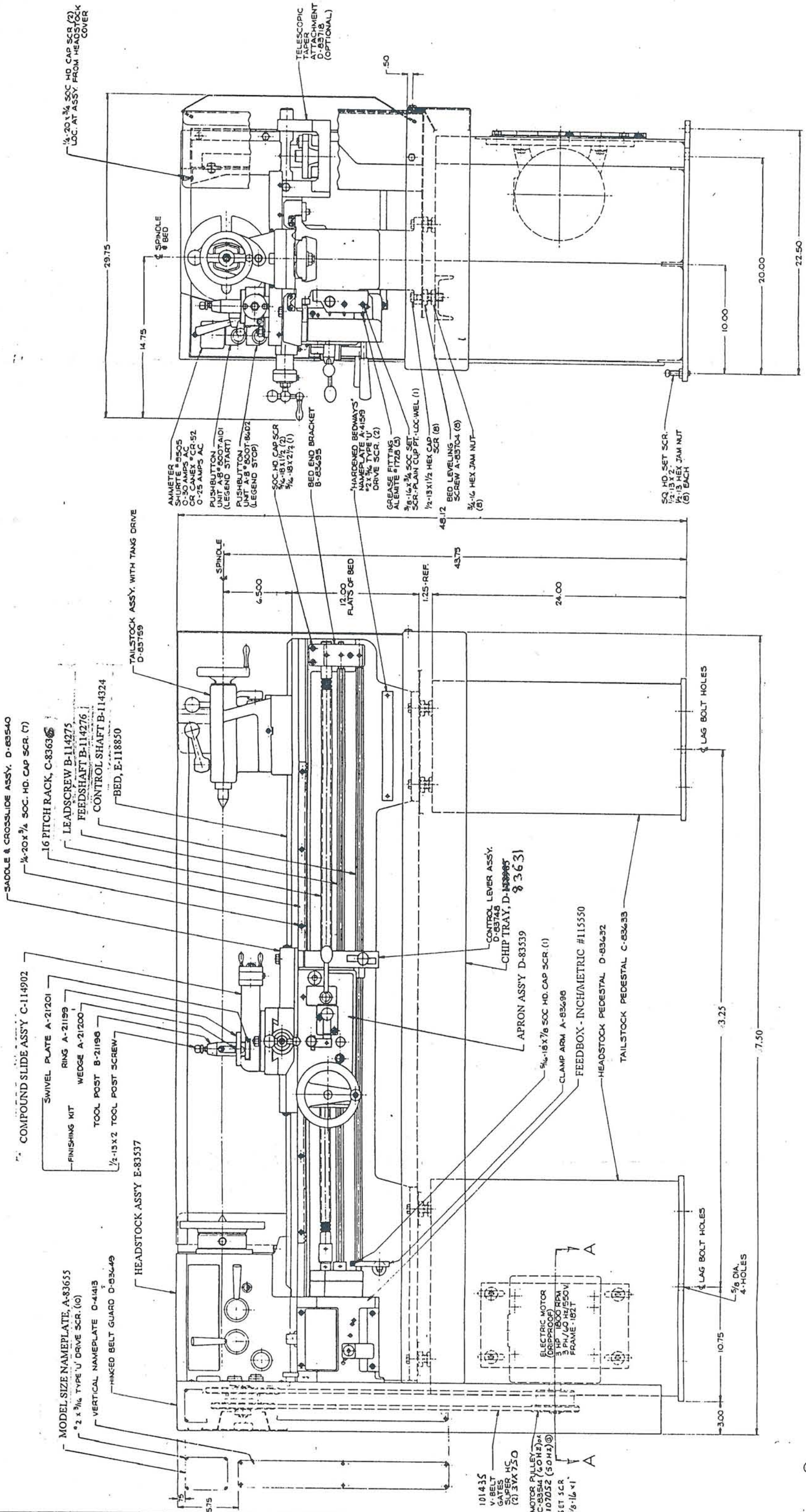

(B) OPTIONAL MOTOR 3HP 1500RPM 50HZ

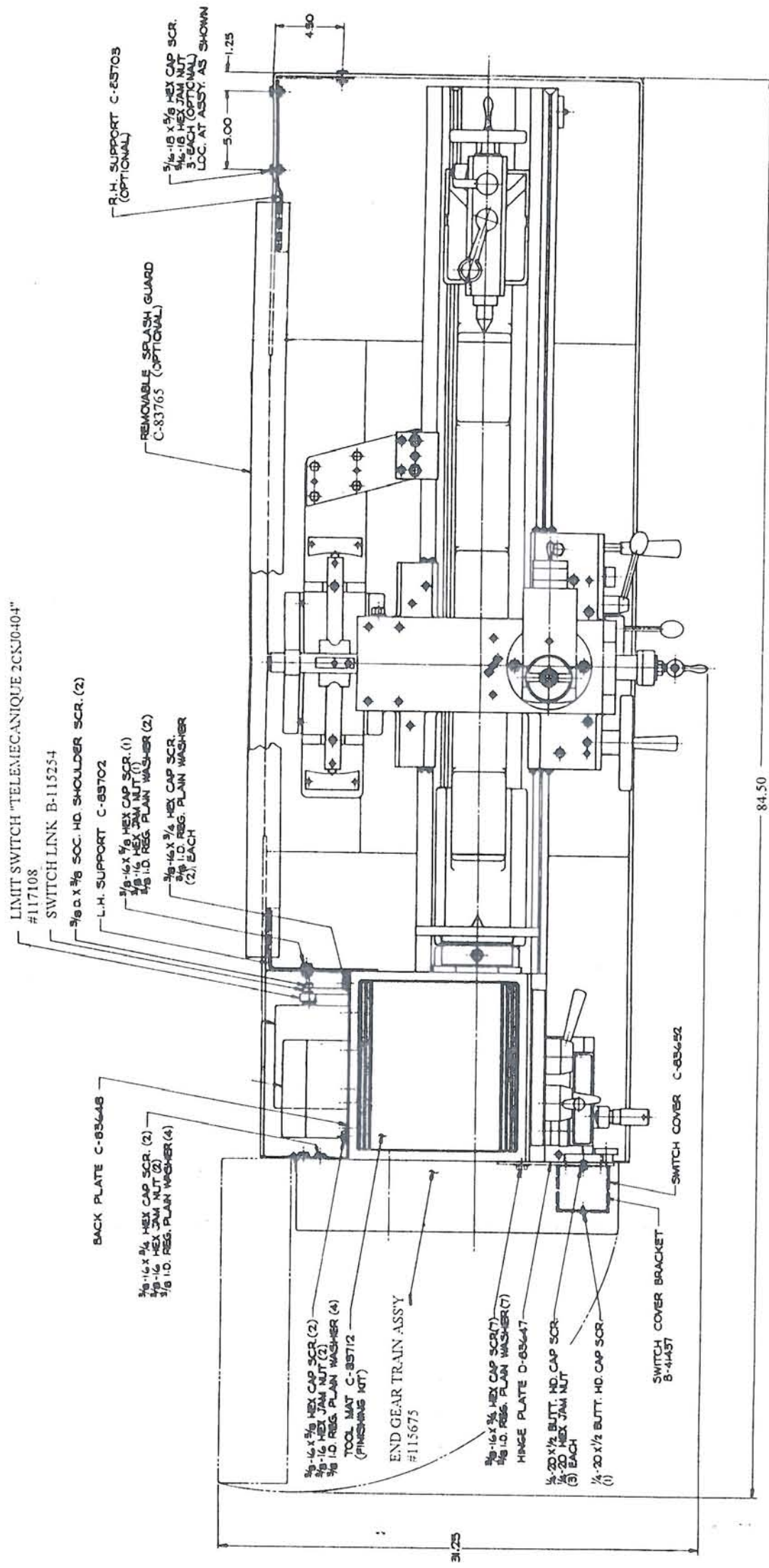

- OPTIONAL EQUIPMENT (SHOWN)
- TELESCOPIC TAPER ATTACHMENT ASSY. — D-83718
 - REMOVABLE SPLASH GUARD, C-83765

- OPTIONAL EQUIPMENT (NOT SHOWN)
- STEADY REST ASSY. — C-30667
 - FOLLOW REST ASSY. C-108972
 - 10" FACEPLATE ASSY #32191
 - 12" FACEPLATE ASSY C-32193
 - MICROMETER CARRIAGE STOP ASSY C-83713
 - DEPTH THREADING STOP ASSY. — D-83746
 - COLLET ATTACHMENT ASSY. FOR 5C COLLET — C-83710
 - COOLANT ASSY. — D-83760
 - COLLET RACK ASSY. — D-83780

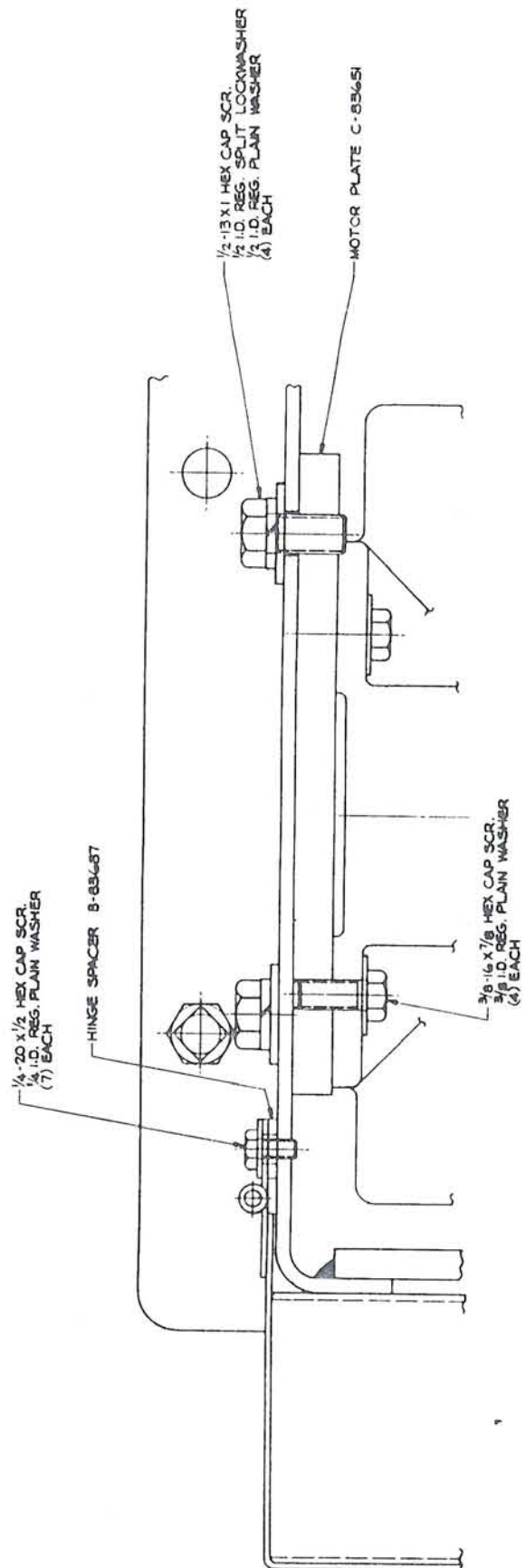

PARTIAL SECTION A-A
SCALE: FULL SIZE

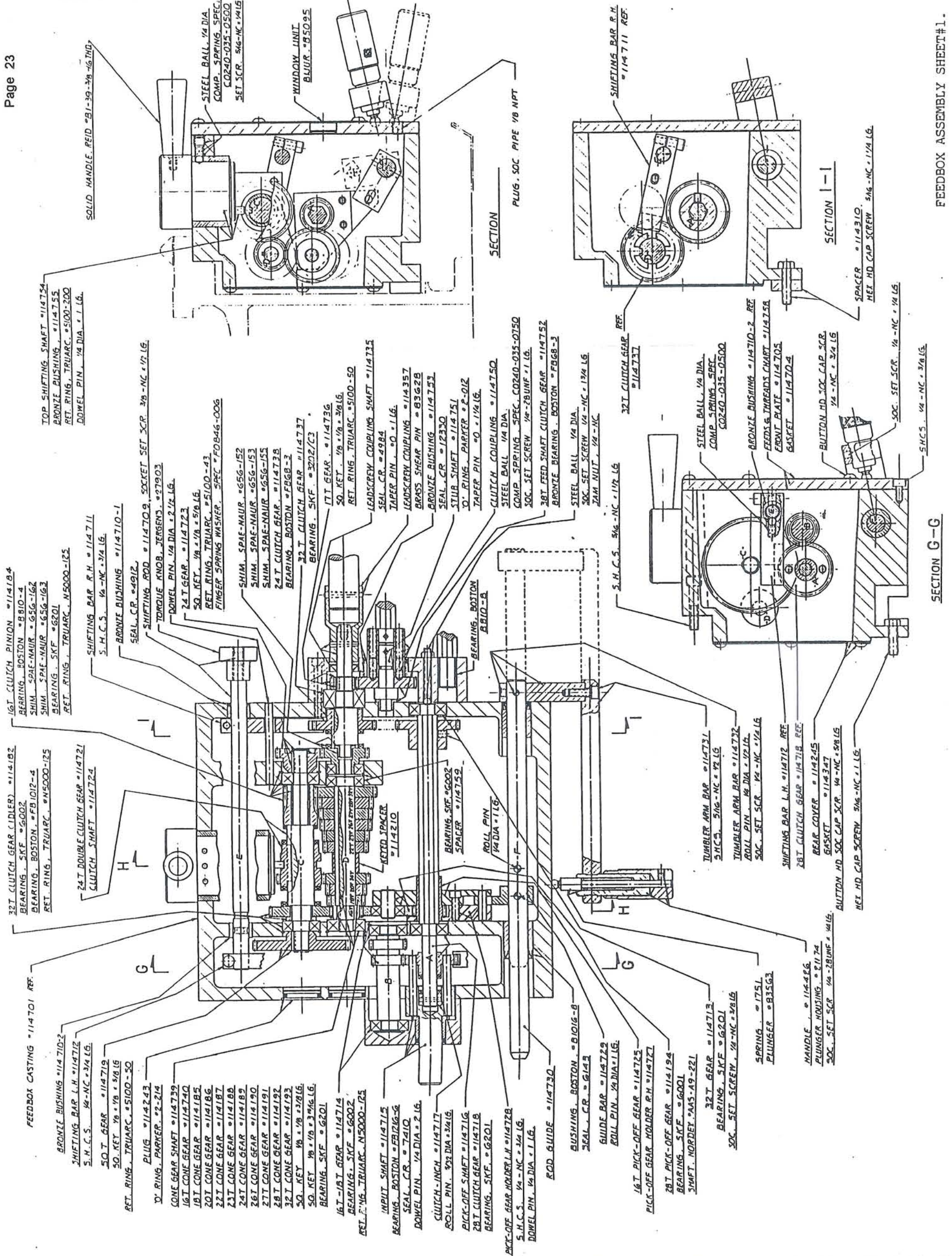

- 32T CLUTCH GEAR (DILDER) #114182
- BEARING, BOSTON #8810-4
- SHIM, SPAE-NAUR #656-162
- SHIM, SPAE-NAUR #656-163
- BEARING, SKF #6201
- RET. RING, TRIARC. #N5000-125
- SHIFTING BAR R.H. #114711
- S.H.C.S. 1/4-NC-3/4 LG.
- BRONZE BUSHING #114710-1
- SEAL, C.R. #4912
- SHIFTING ROD #114709, SOCKET SET SCR. 3/8-NC-1/2 LG.
- TORQUE KNOB, JERGENS. #27903
- DOWEL PIN, 1/4 DIA. #2 1/2 LG.
- 24T GEAR #114723
- SO. KEY 1/8 x 1/8 x 5/16 LG.
- RET. RING, TRIARC. #5100-43
- FINGER SPRING WASHER, SPEC #FOB46-006
- SHIM, SPAE-NAUR #656-152
- SHIM, SPAE-NAUR #656-153
- SHIM, SPAE-NAUR #656-155
- 24T CLUTCH GEAR #114739
- BEARING, BOSTON #FB68-3
- 32T CLUTCH GEAR #114737
- BEARING, SKF #3202/C3
- 11T GEAR #114736
- SO. KEY 1/8 x 1/8 x 3/16 LG.
- RET. RING, TRIARC. #5100-50
- LEADSCREW COUPLING SHAFT #114735
- SEAL, C.R. #4984
- TAPER PIN #0-1 LG.
- LEADSCREW COUPLING #114357
- BRASS SHEAR PIN #83628
- BRONZE BUSHING #114733
- SEAL, C.R. #12350
- SHAFT SHAFT #114751
- O-RING, PARKER #2-012
- TAPER PIN #0-1/4 LG.
- CLUTCH COUPLING #114750
- STEEL BALL 1/4 DIA.
- COMP. SPRING, SPEC. C0240-035-0750
- SO. SET SCREW 1/4-28UNF-1 LG.
- 38T FEED SHAFT CLUTCH GEAR #114752
- BRONZE BEARING, BOSTON #FB68-3
- STEEL BALL 1/4 DIA.
- SO. SET SCREW 1/4-NC-13/4 LG.
- JAM NUT, 1/4-NC

- 16T CLUTCH PINION #114184
- SHIM, SPAE-NAUR #8810-4
- SHIM, SPAE-NAUR #656-162
- SHIM, SPAE-NAUR #656-163
- BEARING, SKF #6201
- RET. RING, TRIARC. #N5000-125
- SHIFTING BAR R.H. #114711
- S.H.C.S. 1/4-NC-3/4 LG.
- BRONZE BUSHING #114710-1
- SEAL, C.R. #4912
- SHIFTING ROD #114709, SOCKET SET SCR. 3/8-NC-1/2 LG.
- TORQUE KNOB, JERGENS. #27903
- DOWEL PIN, 1/4 DIA. #2 1/2 LG.
- 24T GEAR #114723
- SO. KEY 1/8 x 1/8 x 5/16 LG.
- RET. RING, TRIARC. #5100-43
- FINGER SPRING WASHER, SPEC #FOB46-006
- SHIM, SPAE-NAUR #656-152
- SHIM, SPAE-NAUR #656-153
- SHIM, SPAE-NAUR #656-155
- 24T CLUTCH GEAR #114739
- BEARING, BOSTON #FB68-3
- 32T CLUTCH GEAR #114737
- BEARING, SKF #3202/C3
- 11T GEAR #114736
- SO. KEY 1/8 x 1/8 x 3/16 LG.
- RET. RING, TRIARC. #5100-50
- LEADSCREW COUPLING SHAFT #114735
- SEAL, C.R. #4984
- TAPER PIN #0-1 LG.
- LEADSCREW COUPLING #114357
- BRASS SHEAR PIN #83628
- BRONZE BUSHING #114733
- SEAL, C.R. #12350
- SHAFT SHAFT #114751
- O-RING, PARKER #2-012
- TAPER PIN #0-1/4 LG.
- CLUTCH COUPLING #114750
- STEEL BALL 1/4 DIA.
- COMP. SPRING, SPEC. C0240-035-0750
- SO. SET SCREW 1/4-28UNF-1 LG.
- 38T FEED SHAFT CLUTCH GEAR #114752
- BRONZE BEARING, BOSTON #FB68-3
- STEEL BALL 1/4 DIA.
- SO. SET SCREW 1/4-NC-13/4 LG.
- JAM NUT, 1/4-NC

- FEEDBOX CASTING #114701 REF.
- BRONZE BUSHING #114710-2
- SHIFTING BAR L.H. #114712
- S.H.C.S. 1/4-NC-3/4 LG.
- SO. KEY #114719
- SO. KEY 1/8 x 1/8 x 5/16 LG.
- RET. RING, TRIARC. #5100-50
- PLUNG #114243
- O-RING, PARKER. #2-214
- CONE GEAR SHAFT #114739
- 16T CONE GEAR #114740
- 18T CONE GEAR #114185
- 20T CONE GEAR #114186
- 22T CONE GEAR #114187
- 23T CONE GEAR #114188
- 24T CONE GEAR #114189
- 26T CONE GEAR #114190
- 27T CONE GEAR #114191
- 28T CONE GEAR #114192
- 32T CONE GEAR #114193
- SO. KEY 1/8 x 1/8 x 3/16 LG.
- SO. KEY 1/8 x 1/8 x 5/16 LG.
- BEARING, SKF #6201
- 16T-18T GEAR #114714
- BEARING, SKF #6602
- RET. RING, TRIARC. #N5000-125
- INPUT SHAFT #114715
- BEARING, BOSTON #FB1216-6
- SEAL, C.R. #7410
- DOWEL PIN, 1/4 DIA. #2 LG.
- CLUTCH-INCH #114717
- ROLL PIN, 9/32 DIA. #3/4 LG.
- PICK-OFF SHAFT #114716
- 28T CLUTCH GEAR #114718
- BEARING, SKF #6201
- PICK-OFF GEAR HOLDER L.H. #114728
- S.H.C.S. 1/4-NC-3/4 LG.
- DOWEL PIN, 1/4 DIA. #1 LG.
- ROD GUIDE #114730
- BUSHING, BOSTON #B1016-B
- SEAL, C.R. #6143
- GUIDE BAR #114729
- ROLL PIN, 1/4 DIA. #1 LG.
- 16T PICK-OFF GEAR #114725
- PICK-OFF GEAR HOLDER R.H. #114727
- 28T PICK-OFF GEAR #114194
- BEARING, SKF #6201
- SHAFT, NORDEY #AAS-A9-221
- 32T GEAR #114713
- BEARING, SKF #6201
- SO. SET SCREW, 1/4-NC-3/8 LG.
- SPRING #1751
- PLUNGER #83563
- HANDLE #114426
- PLUNGER HOUSING #81724
- SO. SET SCR 1/4-28UNF # 1/4 LG.

- TOP SHIFTING SHAFT #114754
- BRONZE BUSHING #114755
- RET. RING, TRIARC. #5100-200
- DOWEL PIN, 1/4 DIA. #1 LG.
- SOLID HANDLE, REID #81-39-3/8-1/6 THD.
- STEEL BALL, 1/4 DIA. COMP. SPRING, SPEC. C0240-035-0500
- SET SCR. 5/16-NC-1/4 LG.
- WINDOW UNIT BUJUR. #85025
- PLUG, SOC PIPE 1/8 NPT
- SHIFTING BAR R.H. #114711 REF.
- SPACEFR #114310, HEX HD CAP SCREW 5/16-NC-1/4 LG.
- SO. SET SCR. 1/4-NC-1/4 LG.
- SHCS 1/4-NC-3/8 LG.
- 32T CLUTCH GEAR #114737
- STEEL BALL, 1/4 DIA. COMP. SPRING, SPEC. C0240-035-0500
- BRONZE BUSHING #114710-2 REF.
- FEEDS & THREADS CHART #114758
- FRONT PLATE #114705
- GASKET #114704
- BUJON HD SOC CAP SCR 1/4-NC-3/4 LG.
- SO. SET SCR. 1/4-NC-1/4 LG.
- SHCS 1/4-NC-3/8 LG.

- 16T CLUTCH GEAR #114731
- S.H.C.S. 5/16-NC-1/2 LG.
- TUMBLER ARM BAR #114732
- S.H.C.S. 5/16-NC-1/2 LG.
- TUMBLER ARM BAR #114732
- ROLL PIN, 1/4 DIA. #1/2 LG.
- SO. SET SCR. 1/4-NC-1/4 LG.
- SHIFTING BAR L.H. #114712 REF.
- 28T CLUTCH GEAR #114718 REF.
- BEAR COVER #114245
- GASKET #114347
- BUJON HD SOC CAP SCR 1/4-NC-5/8 LG.
- HEX HD CAP SCREW 5/16-NC-1 LG.

- 24T DOUBLE CLUTCH GEAR #114721
- CLUTCH SHAFT #114724
- BEARING, BOSTON #B810-B
- BEARING, SKF #6002
- SPACER #114210
- ROLL PIN 1/4 DIA. #1 LG.
- BEARING, BOSTON #B810-B
- CLUTCH COUPLING #114750
- STEEL BALL 1/4 DIA.
- COMP. SPRING, SPEC. C0240-035-0750
- SO. SET SCREW 1/4-28UNF-1 LG.
- 38T FEED SHAFT CLUTCH GEAR #114752
- BRONZE BEARING, BOSTON #FB68-3
- STEEL BALL 1/4 DIA.
- SO. SET SCREW 1/4-NC-13/4 LG.
- JAM NUT, 1/4-NC
- 5.H.C.S. 5/16-NC-1/2 LG.
- 32T CLUTCH GEAR #114737
- STEEL BALL, 1/4 DIA. COMP. SPRING, SPEC. C0240-035-0500
- BRONZE BUSHING #114710-2 REF.
- FEEDS & THREADS CHART #114758
- FRONT PLATE #114705
- GASKET #114704
- BUJON HD SOC CAP SCR 1/4-NC-3/4 LG.
- SO. SET SCR. 1/4-NC-1/4 LG.
- SHCS 1/4-NC-3/8 LG.

- 32T CLUTCH GEAR #114731
- STEEL BALL, 1/4 DIA. COMP. SPRING, SPEC. C0240-035-0500
- BRONZE BUSHING #114710-2 REF.
- FEEDS & THREADS CHART #114758
- FRONT PLATE #114705
- GASKET #114704
- BUJON HD SOC CAP SCR 1/4-NC-3/4 LG.
- SO. SET SCR. 1/4-NC-1/4 LG.
- SHCS 1/4-NC-3/8 LG.

- SECTION G-G
- SECTION I-I
- SECTION
- PLUG, SOC PIPE 1/8 NPT
- SHIFTING BAR R.H. #114711 REF.
- SPACEFR #114310, HEX HD CAP SCREW 5/16-NC-1/4 LG.
- SO. SET SCR. 1/4-NC-1/4 LG.
- SHCS 1/4-NC-3/8 LG.

LEADSCREW COUPLING #114357 REF.

LEADSCREW REF.

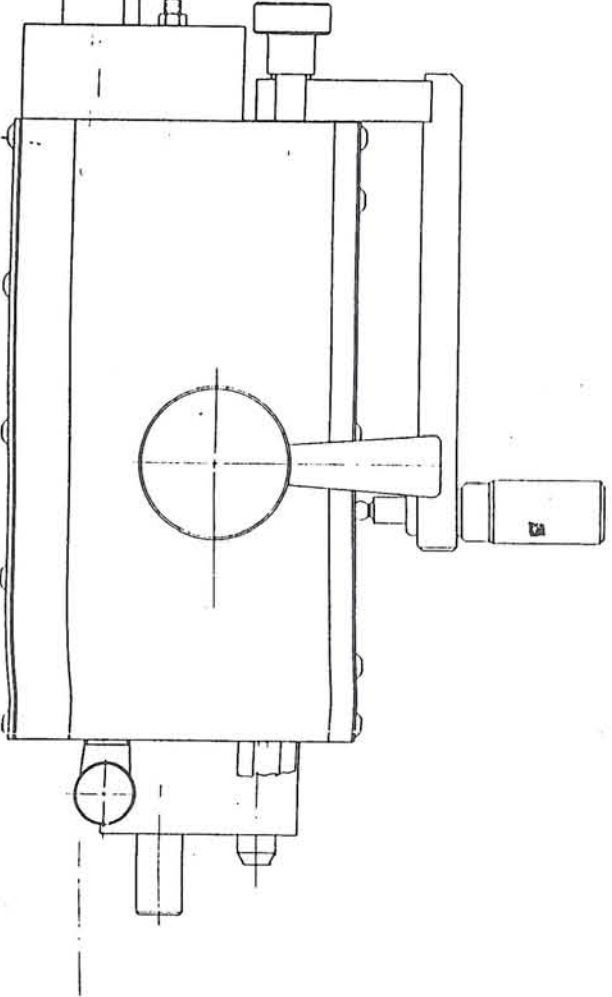

RIGHT COVER #114706
S.H.C.S. 7/4 - NC x 13/4 LG

CLUTCH COUPLING #114750 REF.

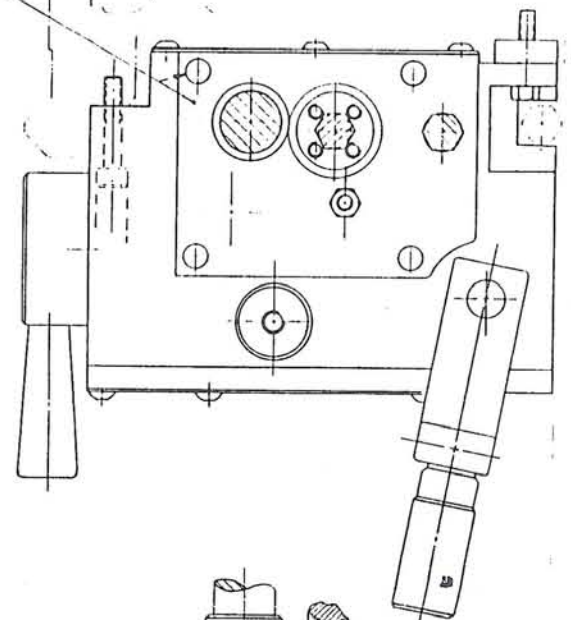

FEED SHAFT REF.

CONTROL SHAFT REF.

FEEDBOX CASTING #114701

OIL CUP, GITS #01402

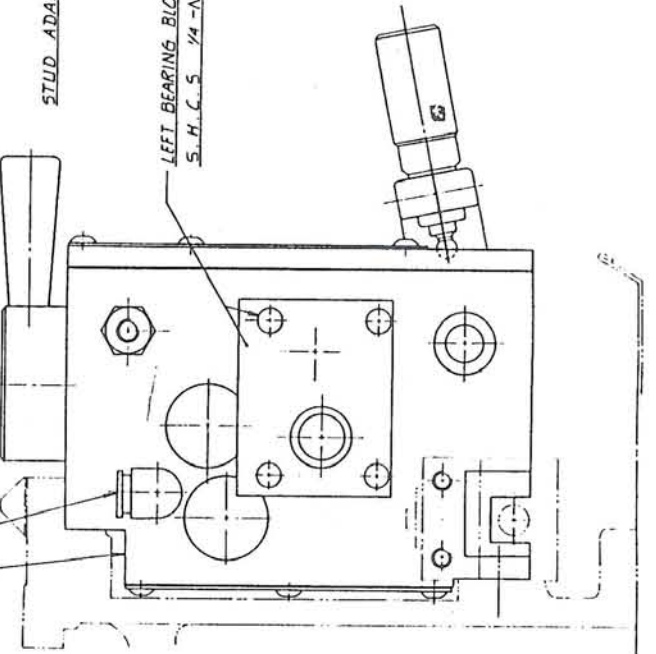

STUD ADAPTER #114757

LEFT BEARING BLOCK #114707
S.H.C.S. 7/4 - NC x 13/4 LG

DATE	BY	CHKD
11/14/57	J. H. G.	J. H. G.
1. UNLESS OTHERWISE SPECIFIED DIMENSIONS ARE IN INCHES FINISHES ARE AS SHOWN TOLERANCES ARE: FRACTIONS DECIMALS .0005 .0001 .001 .0002 .005 .0005 .010 .0010 .030 .0030 .060 .0060 .125 .0125 .250 .0250 .500 .0500 1.000 .1000 2.000 .2000 3.000 .3000 4.000 .4000 5.000 .5000 6.000 .6000 7.000 .7000 8.000 .8000 9.000 .9000 10.000 1.0000		

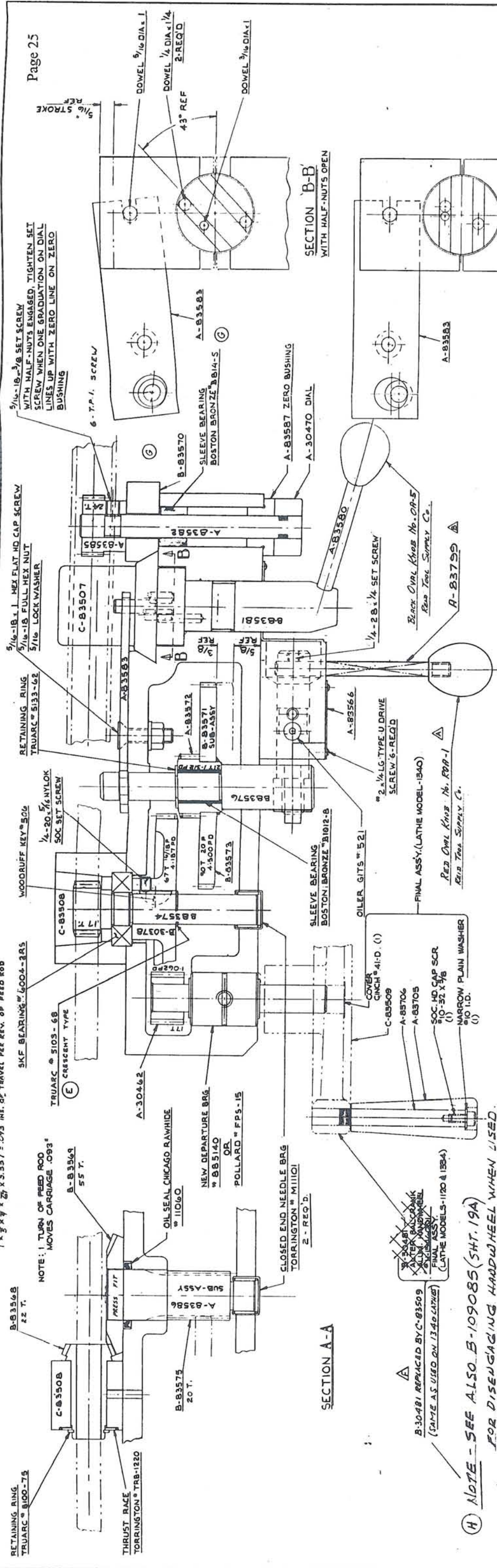

SECTION A-A

SECTION B-B WITH HALF-NUTS OPEN

SECTION B-B WITH HALF-NUTS CLOSED

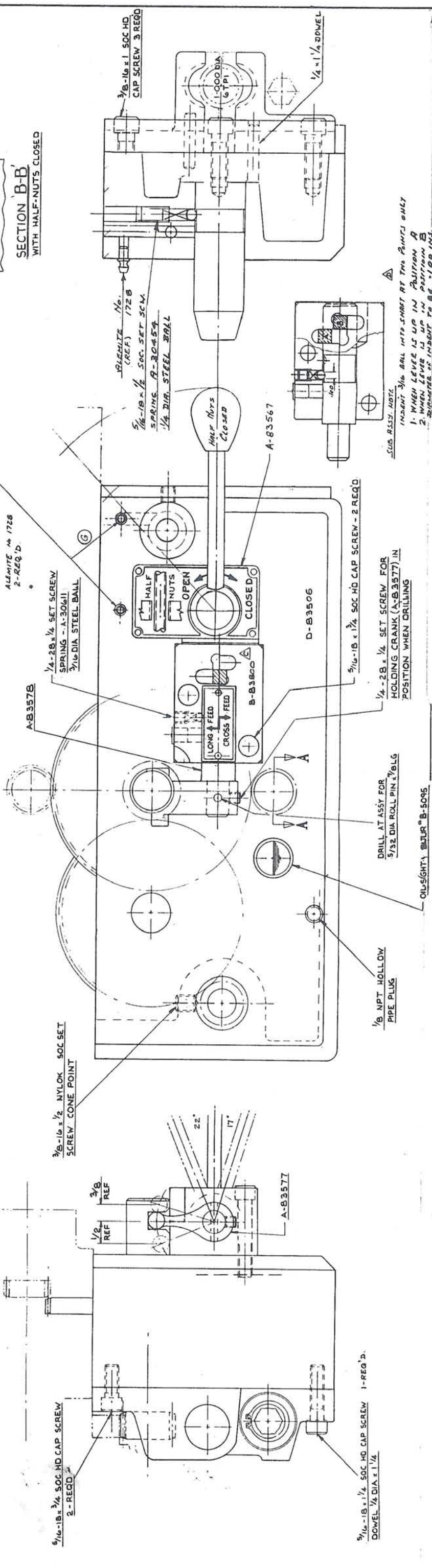

APRON ASSEMBLY

1 x 3/8 x 3/4 x 3/32 = .093 INS. OF TRAVEL PER REV. OF FEED ROD

NOTE: 1 TURN OF FEED ROD MOVES CARRIAGE .093"

B-30481 REPLACED BY C-83509 (SAME AS USED ON 1340 LATHIE)

NOTE - SEE ALSO B-109085 (SHT. 19A) FOR DISENGAGING HARDWHEEL WHEN USED.

SUB. ASSY. NOTE: INSERT 3/16 BALL INTO SHIRT AT TWO POINTS ONLY 1. WHEN LEVER IS UP IN POSITION A 2. WHEN LEVER IS UP IN POSITION B 3. WRENCH IS INSERT TO BE - 1/8 DIA.

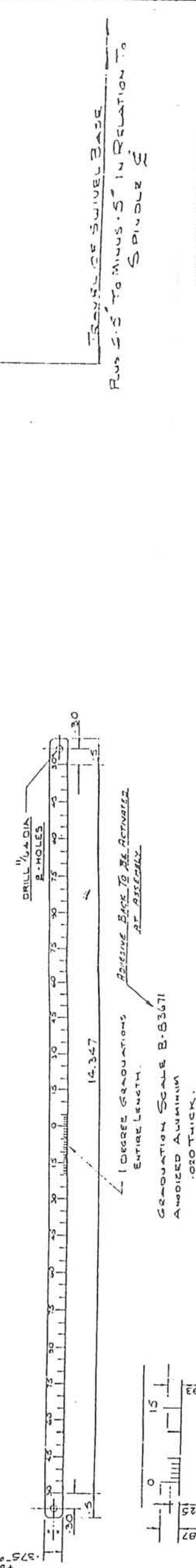
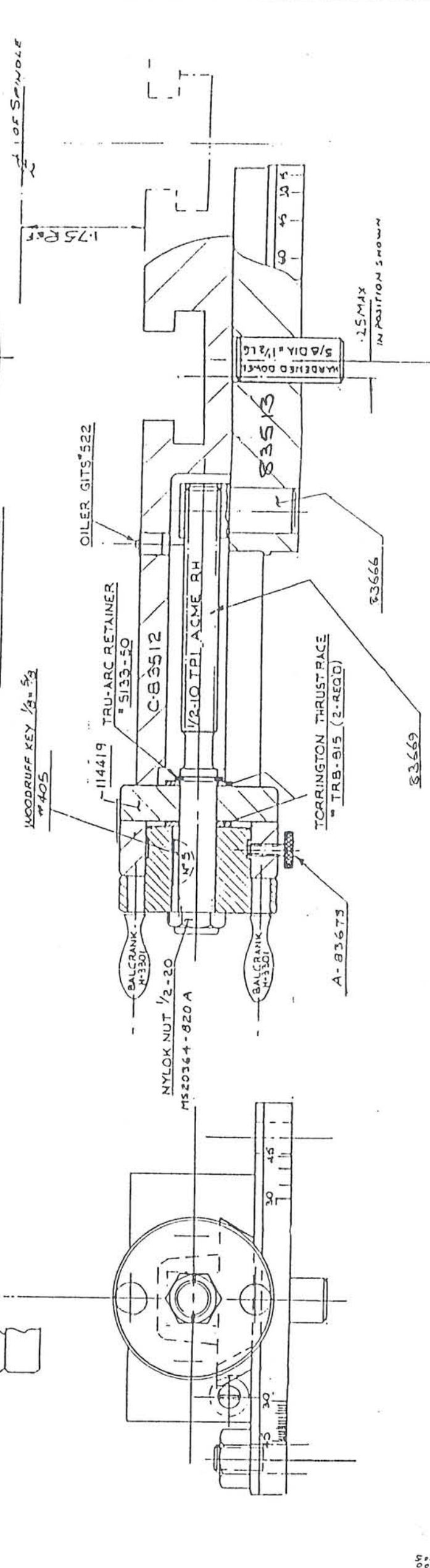
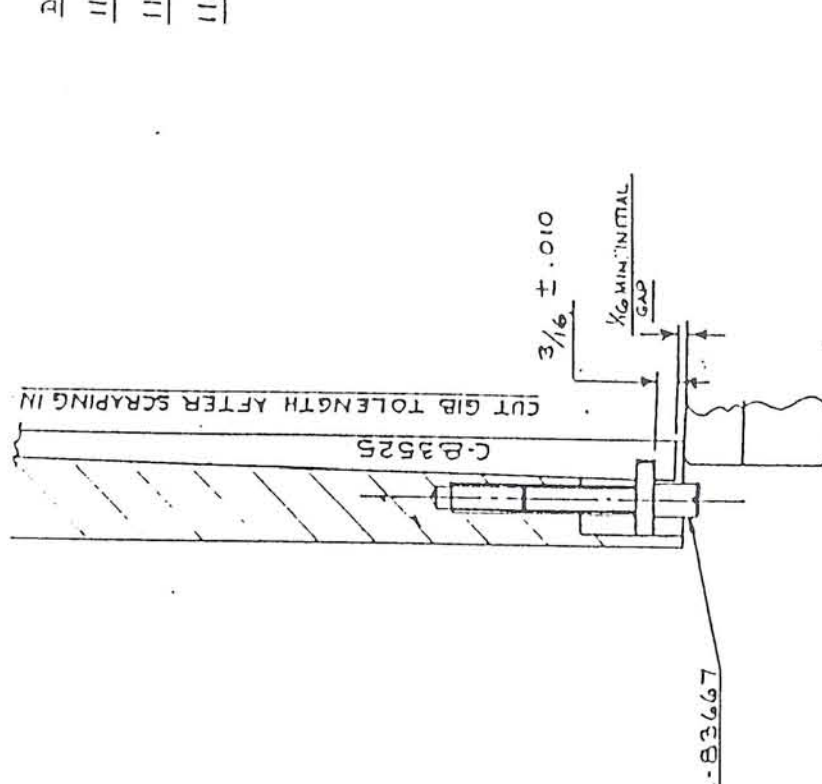
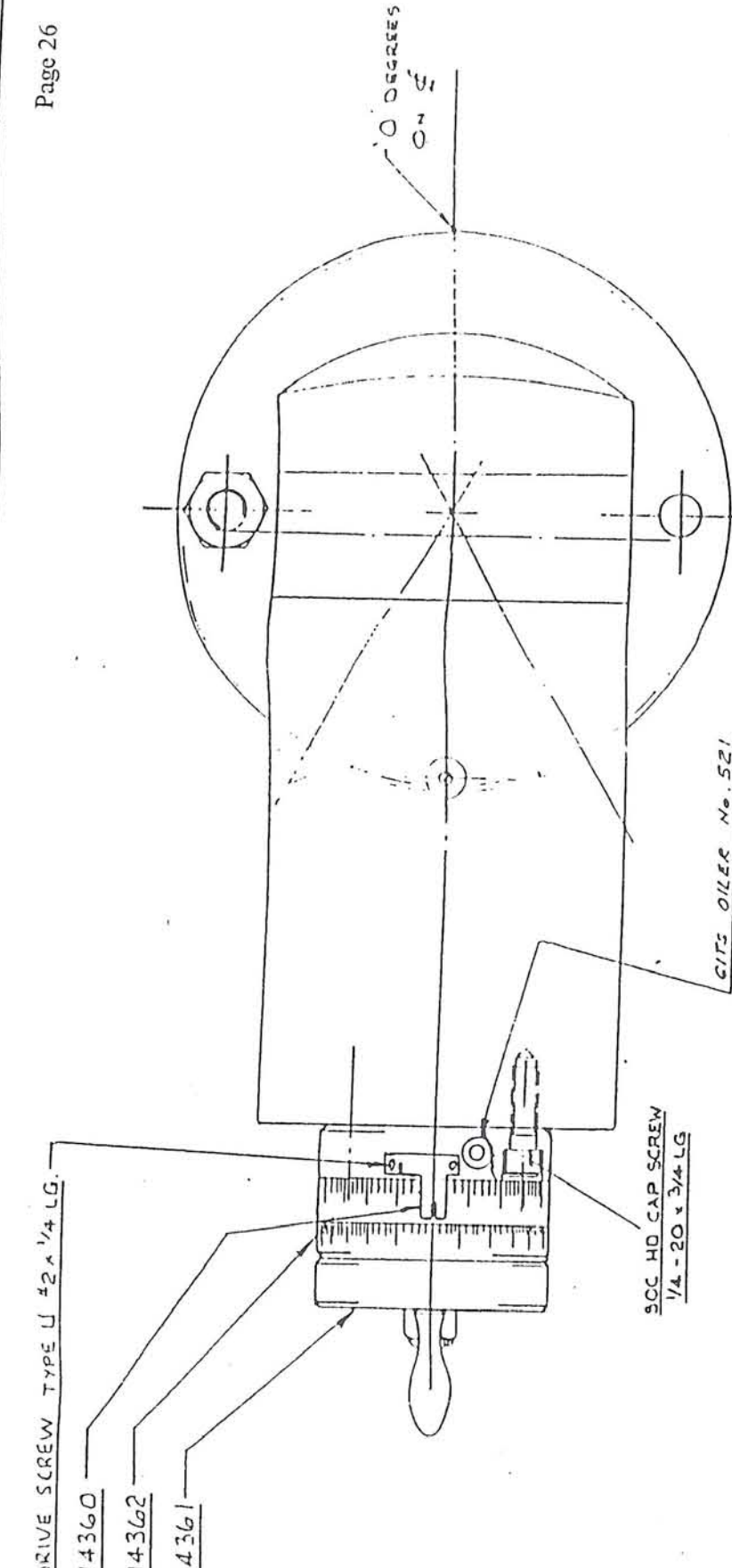

COMPOUND SLIDE ASSEMBLY

TRU-ARC SWIVEL BASE
PLUS .5" TO MINUS .5" IN RELATION TO
SPINDLE

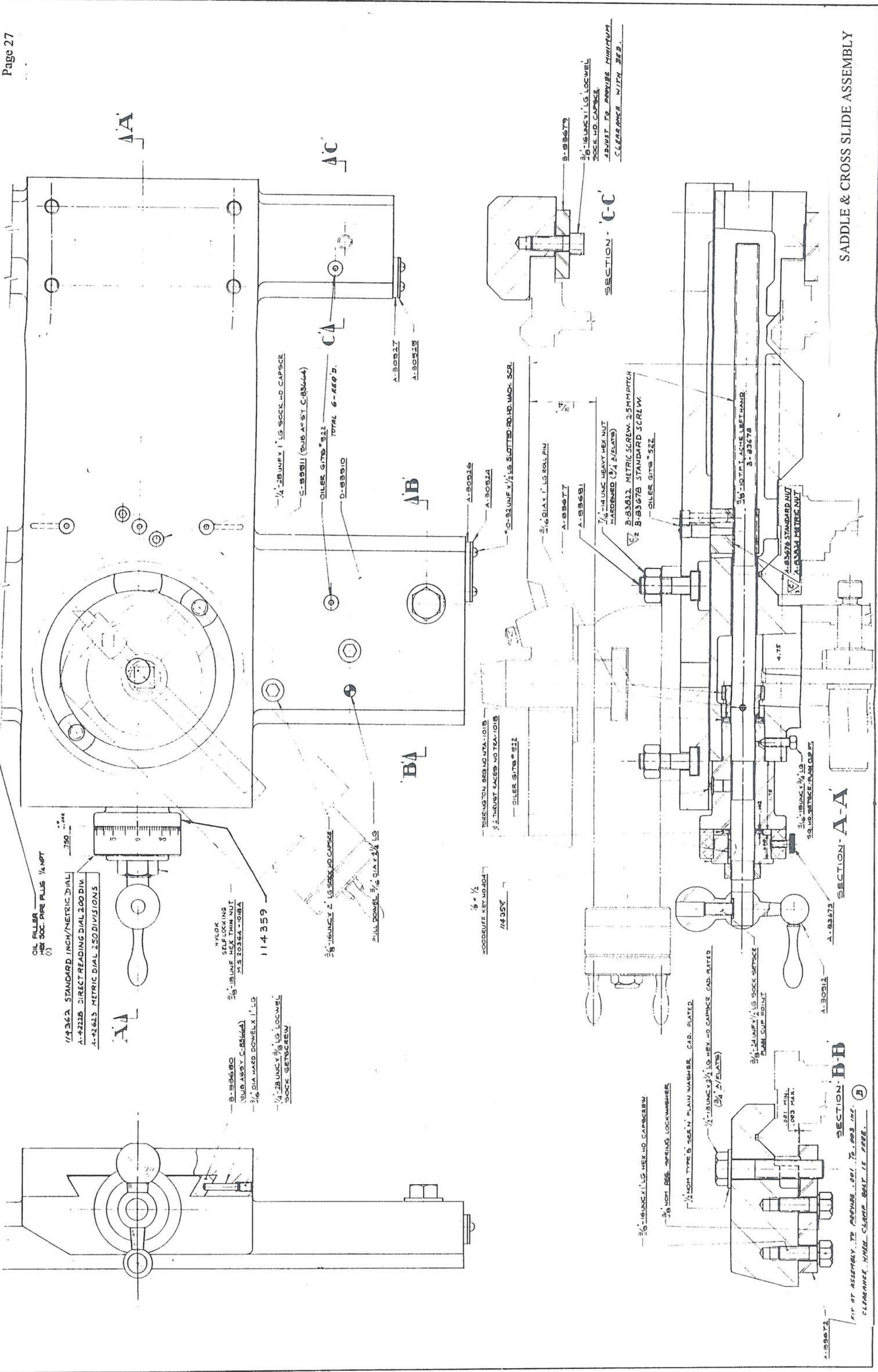

- OIL FILLER
HEX SOC. PIPE PLUS 1/4 NPT
- 1/4 362 STANDARD INCH/METRIC DIAL
- A-4222B DIRECT READING DIAL 300 DIV
- A-42623 METRIC DIAL 250 DIVISIONS
- 750
- NYLON
SELF LOCKING
THIN NUT
- B-89680
1/8 UNF HEX THIN NUT
M.S. 20364-1018A
- 114359
- 1/8 UNF X 2 LG SOCK HD CAPSCR
- 1/8 UNF X 1 LG SOCK HD CAPSCR
- C-89811 (SUB ASSY C-89664)
- OILER GITS #522
- D-89910
- TOTAL 6-KG B.
- PULL DOWEL 3/16 DIA X 1/4 LG
- WOODRUFF KEY NO. 404
- 1/4 357
- 1/8 X 1/2
- A-30524
- A-30524
- 10-32 UNF X 1/2 LG SUTTED RD. HD. MACH. SCR.
- 3/16 DIA X 1 LG ROLL PIN
- A-89677
- A-89681
- 1/4 UNF HEAVY HEX NUT
HARDENED (3/4 A/FINISH)
- B-83612 METRIC SCREW 25MM PITCH
- B-83678 STANDARD SCREW
- OILER GITS #522
- 5/8 10-T.F.I. ACHE LEFT HAND
- B-83678
- A-83676 STANDARD NUT
- A-83684 METRIC NUT
- SECTION A-A
- A-89673
- A-30512
- 3/16 UNF X 1/2 LG
SQ. HD. SETSCREW - PAN. CUP PT.
- 4.75
- SECTION B-B
- 3/8 NOM BEE SPRING LOCKWASHER
- 1/2 NOM TYPE 8 SEEN PLAIN WASHER CAD. PLATED
- 1/8 UNF X 1/2 LG HEV. HD CAPSCR CAD. PLATED
(3/4 A/FINISH)
- 3/8 UNF X 1/2 LG SOCK SETSCREW
PLAIN CUP POINT
- .001 MIN.
.003 MAX.
- SECTION C-C
- 3/16 UNF X 1 LG LOCWEL
SOCK. HD. CAPSCR.
- ADJUST TO PROVIDE MINIMUM
CLEARANCE WITH 362.
- SECTION B-B
- FIT AT ASSEMBLY TO PROVIDE .001 TO .003 INZ.
CLEARANCE WHEN CLAMP BOLT IS FREE.
- A-89672

SADDLE & CROSS SLIDE ASSEMBLY

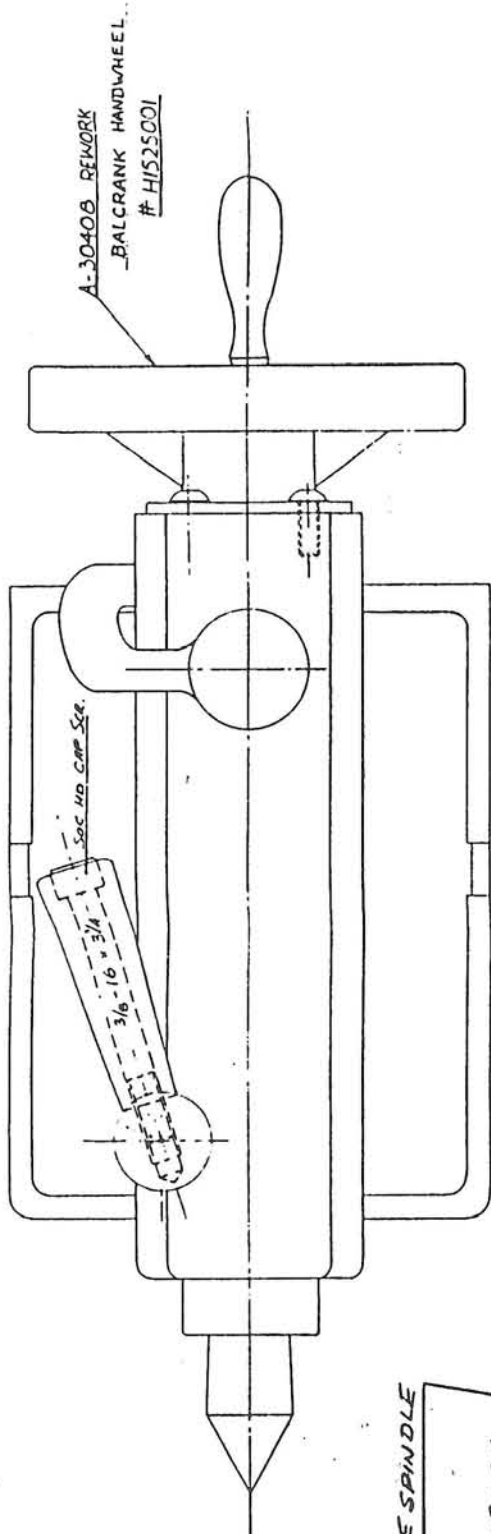

A-3040B REMORK
BALCRANK HANDWHEEL
H1525001

#3 I/M TANGDRIVE SPINDLE
114416

#3 I/M SPINDLE - #109084

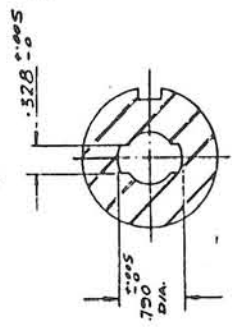

SECTION A-A

O-RING No 219 1 5/16 I.D.
1 9/16 O.D. x 1/8 CROSS-SECTIONAL DIA.

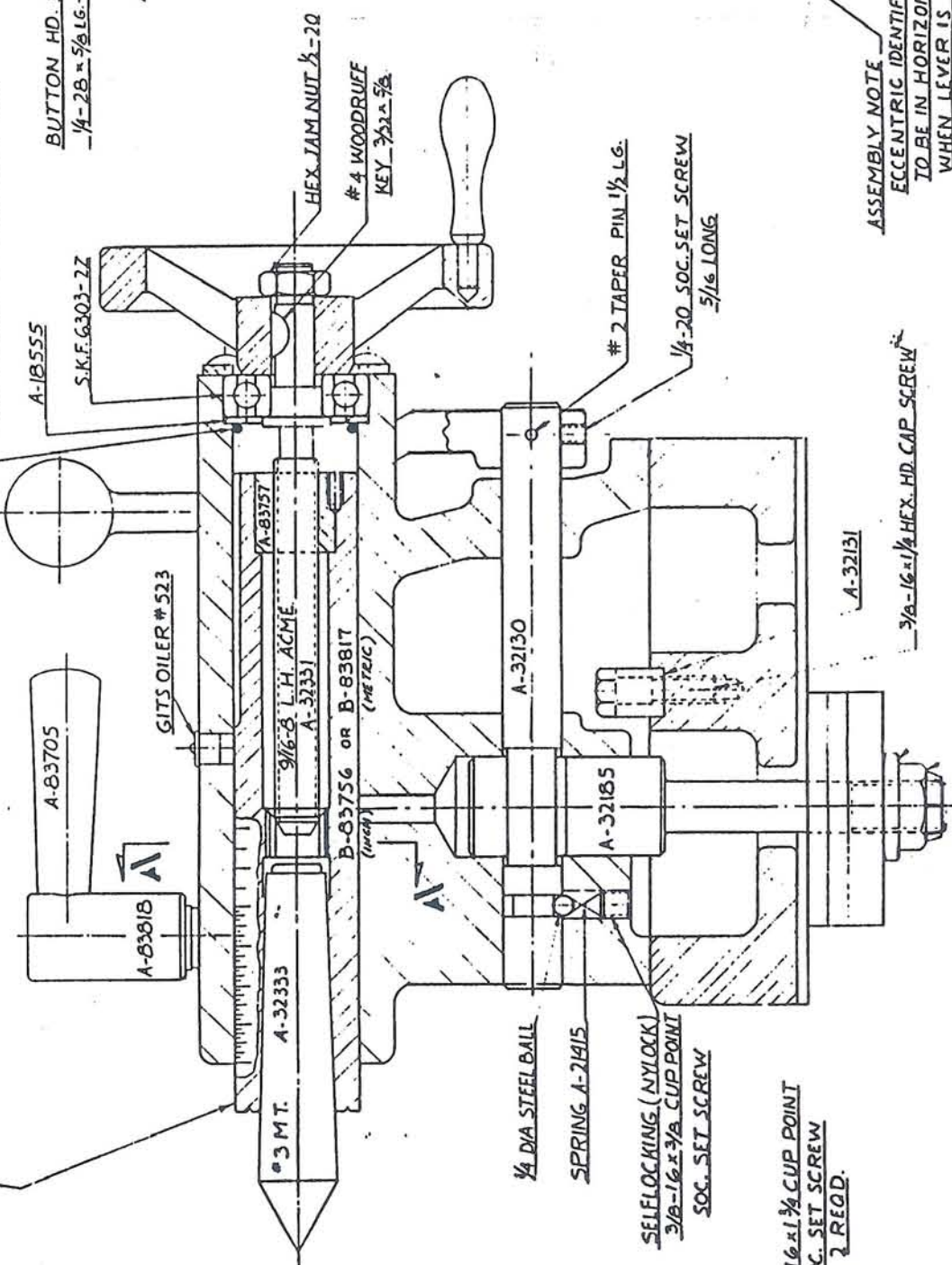

BUTTON HD. SOC. CAP. SCREW
1/4 - 28 x 5/8 LG. - 4 REQD.

A-32335

HEX JAM NUT 1/2 - 20
4 WOODRUFF
KEY 3/32 x 5/8

2 TAPER PIN 1 1/2 LG.
1/4 - 20 SOC. SET SCREW
5/16 LONG

SELELOCKING (NYLON)
3/8 - 16 x 3/8 CUP POINT
SOC. SET SCREW

3/8 - 16 x 1 1/4 CUP POINT
SOC. SET SCREW
2 REQD.

3/8 - 16 x 1/4 HEX. HD. CAP. SCREW

WESPO. WASHER # 6010 1-REQD.

3/8 - 18 N.F. HUGLOCK NUT, 3/16 THICK
1 REQD.

ASSEMBLY NOTE
ECCENTRIC IDENTIFICATION DOT
TO BE IN HORIZONTAL POSITION
WHEN LEVER IS UNCLAMPED

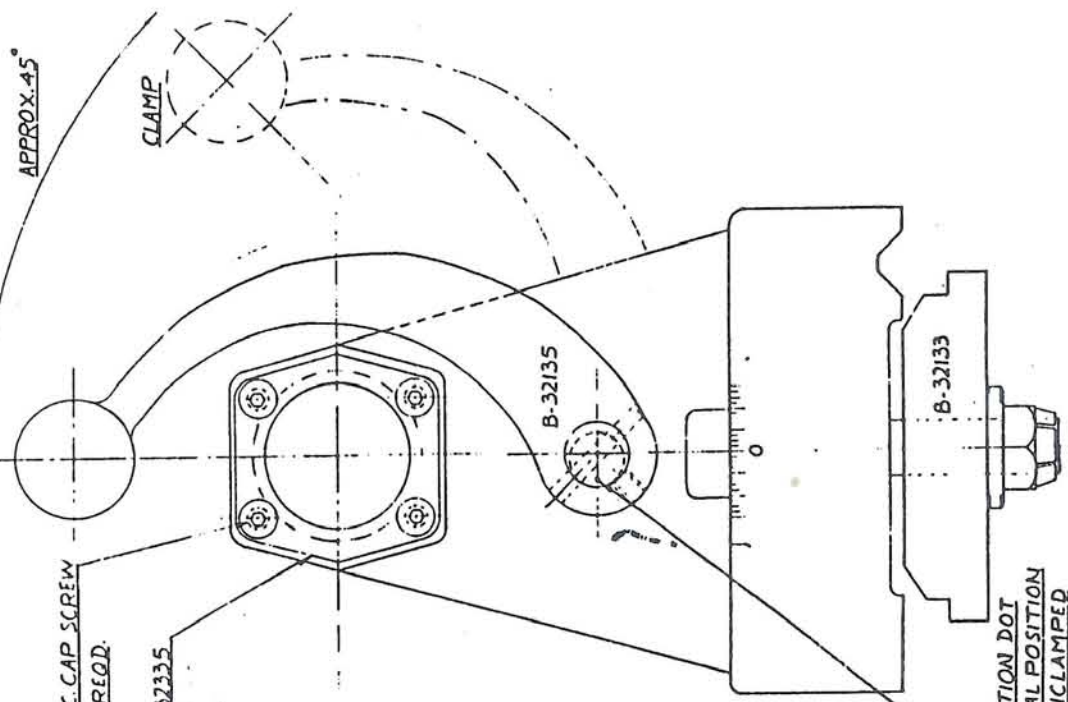

UNCLAMP

APPROX. 45°

CLAMP

B-32135

B-32133

A-32219

D-32125

B-32128

A-32126

C-32156

6.500

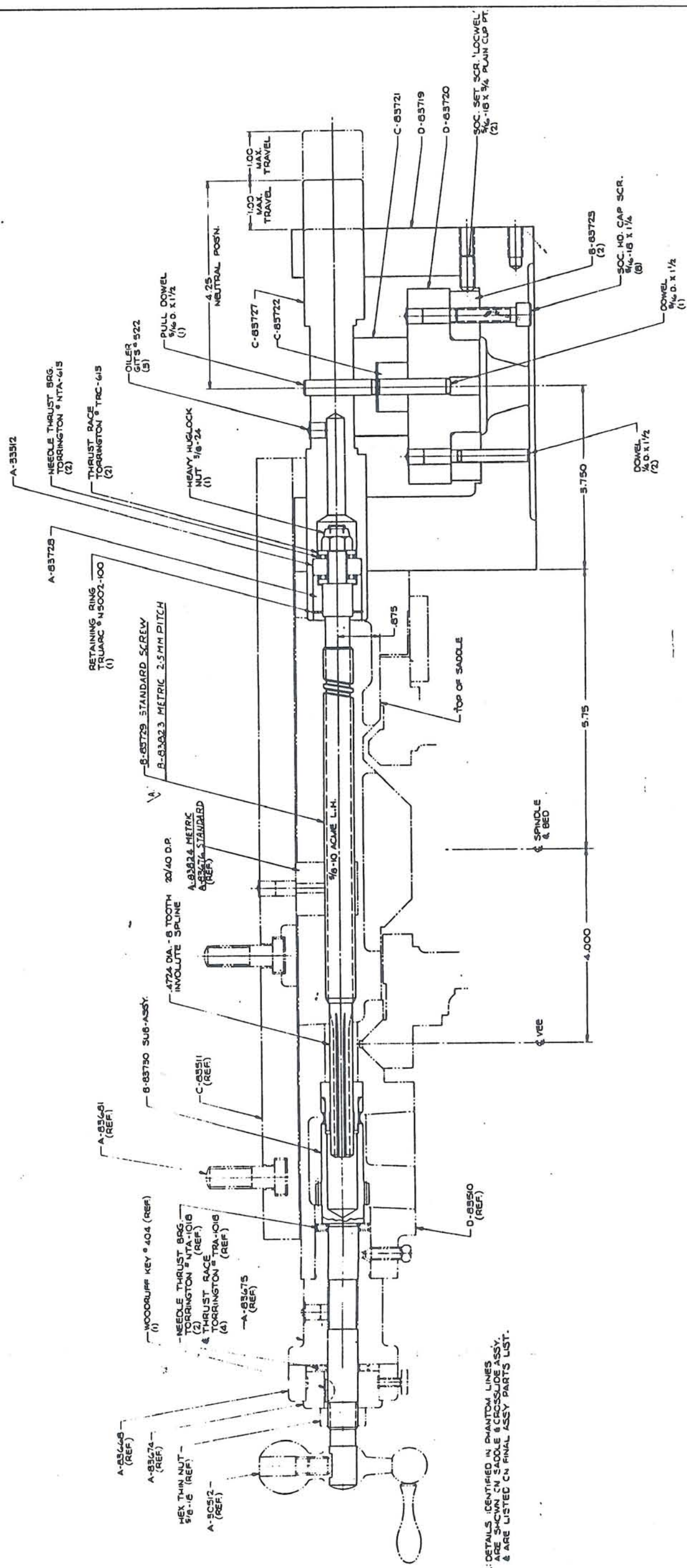

NOTE: DETAILS IDENTIFIED IN PHANTOM LINES ARE SHOWN IN SADDLE & CROSSSLIDE ASSY. & ARE LISTED IN FINAL ASSY PARTS LIST.

THIS ASSY IS NOT COMPLETE WITHOUT SMT 1

TELESCOPIC TAPER ATTACHMENT SHEET #1.

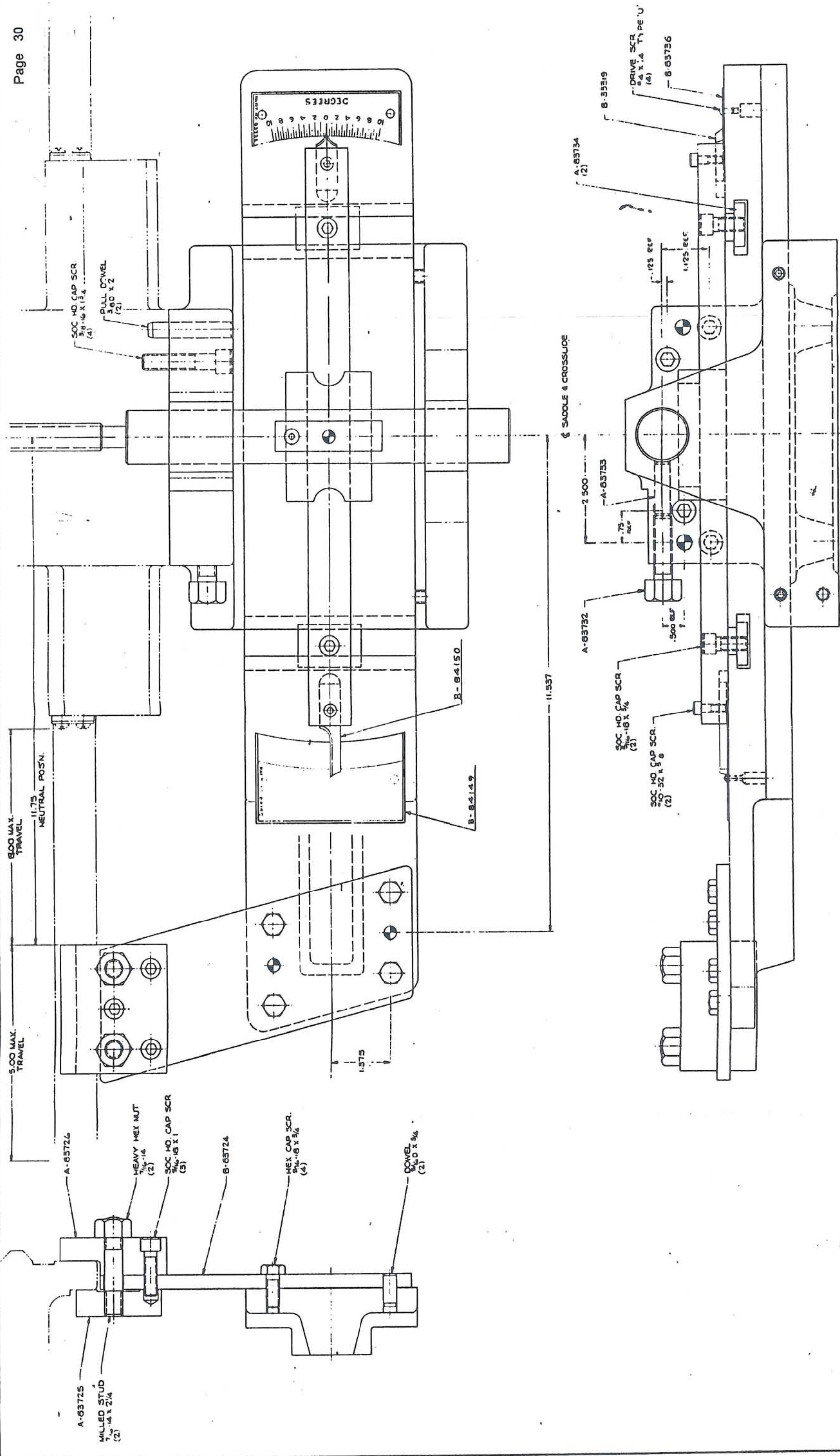

N° 10-32 x 1/4 SOC. SET SCREW - CUP PT. (3-REQ'D)

1/4 - 20 x 3/8 SOC. SET SCREW - CUP PT. (3-REQ'D)

A-30586 (3-REQ'D)

3/8 - 16 HEAVY HEX NUT PERLITON HARD[®] (3-REQ'D)

A-30566 (2-REQ'D)

A-30588 (1-REQ'D)

GROOVE PIN TYPE 2 1/4 DIA. x 1 1/4 LG. (1-REQ'D)

1/8

A-30587 (3-REQ'D)

C-30581 (1-REQ'D)

3/8 - 16 x 1 1/2 SOC. HD CAP SCREW (1-REQ'D)

A-30582 (3-REQ'D)

A-30584 (3-REQ'D)

A-30583 (3-REQ'D)

C-30648 (1-REQ'D)

(B) 3/8 - 16 x 3 MILLED STUD (1-REQ'D)

A-30590 (1-REQ'D)

(1/4 - 3" CAPACITY)

ALSO USED ON LATHE MODELS 1120, 1334, 1340

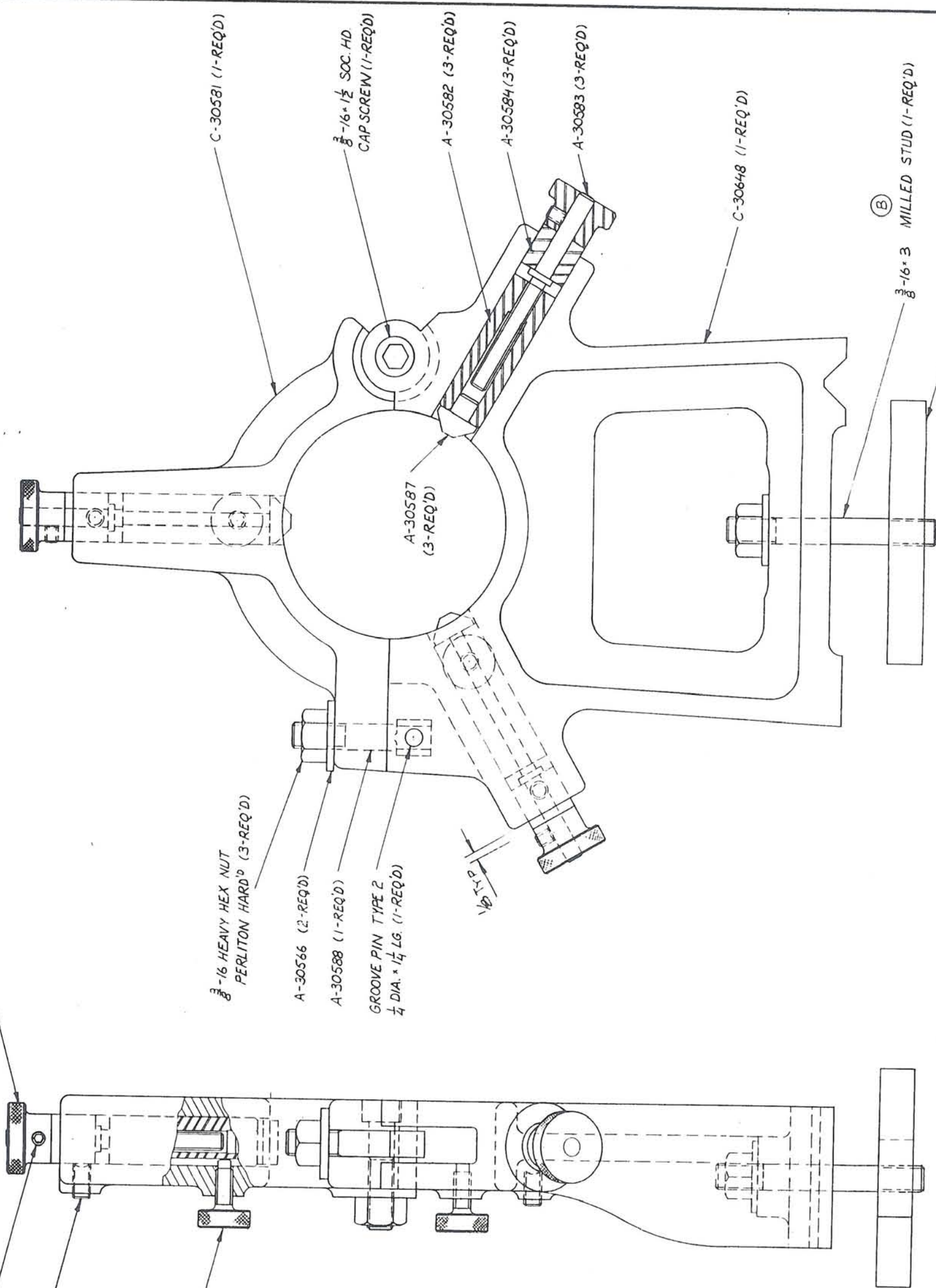

STEADY REST ASSEMBLY

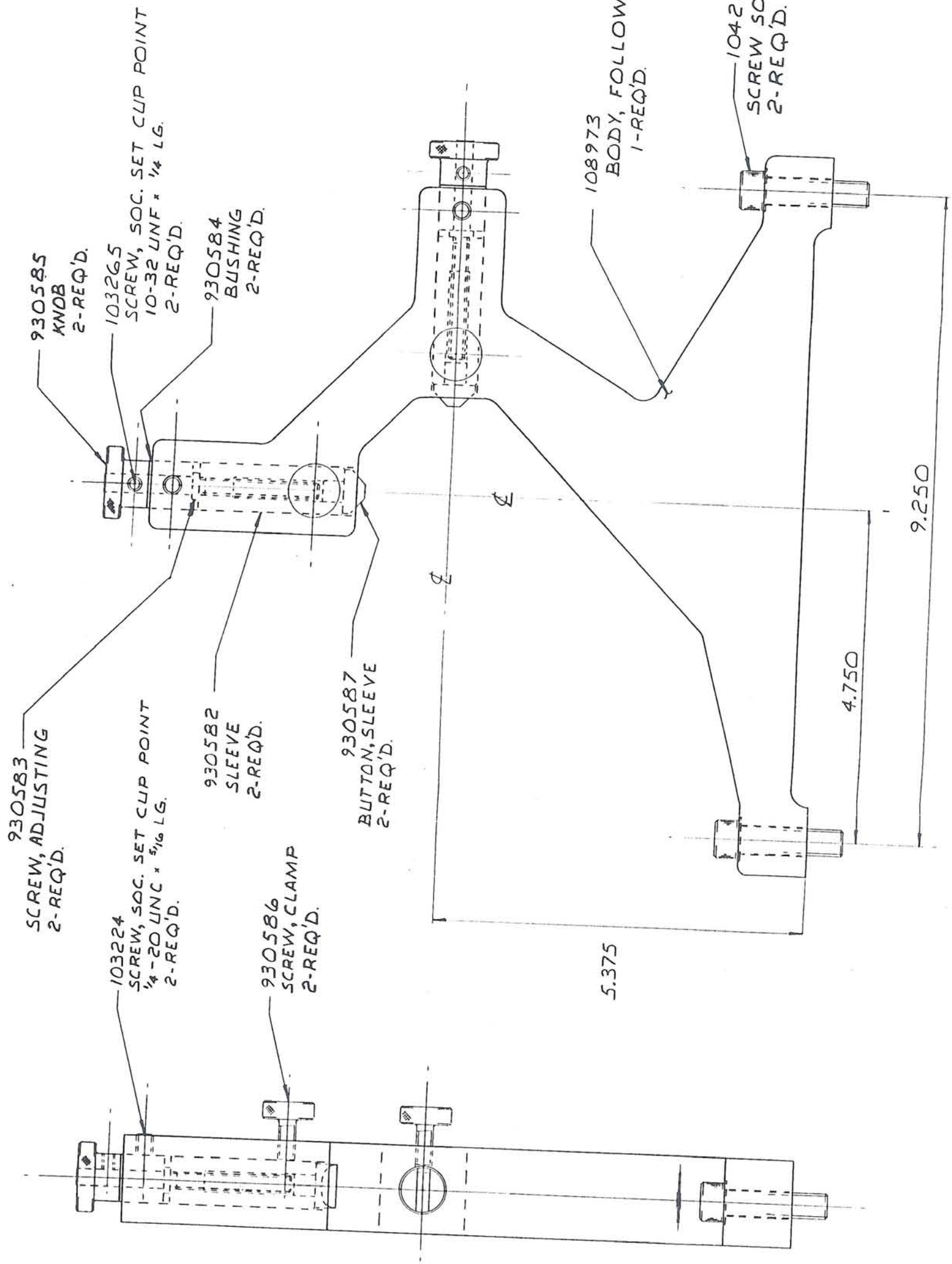

FOLLOW REST ASSEMBLY

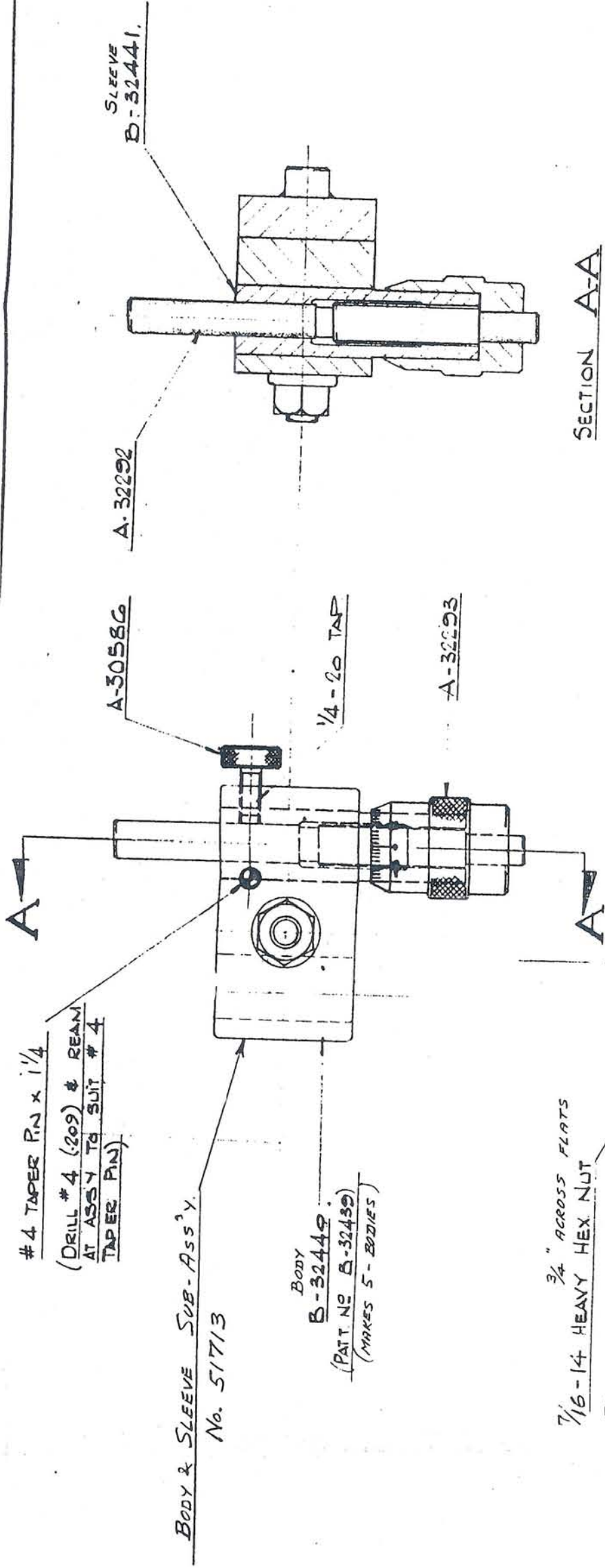

D-32441 TO BE ASSEMBLED WITH GRADUATIONS IN THIS POS'N.

3/16 DIA x 3/4 ROLL PIN

A-83715 SUB ASSY
A-83714 (PLATE)
7/16-14 x 2 3/4 Soc HD CAP SCR

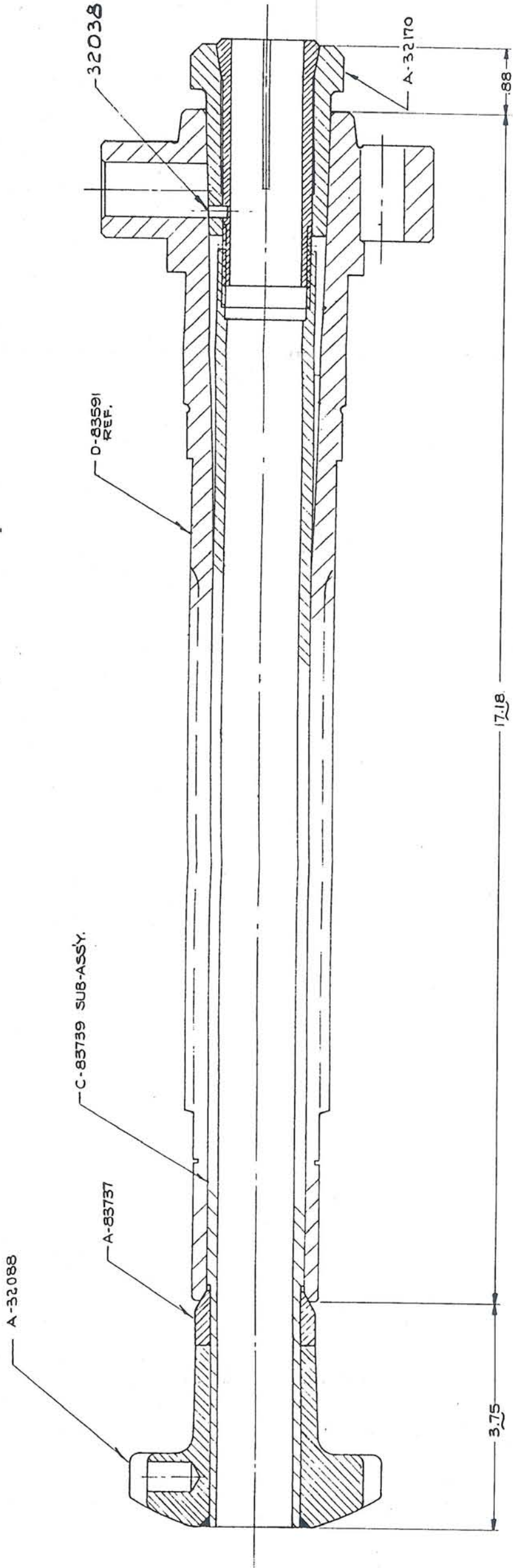

USE HARDINGE $\frac{5}{16}$ " COLLETS
MAXIMUM SIZES AVAILABLE -
 $\frac{1}{16}$ ROUND
 $\frac{7}{8}$ HEXAGON
 $\frac{3}{4}$ SQUARE